



WERKZEUGMASCHINEN GMBH

HOTLINE: +49-6158-84772  
info@gk-werkzeugmaschinen.de

---

Item	Description
------	-------------

---

CNC Vertical Lathe with Standard Accessories

Model : YS-VL-1100HR

**A . Main Specification**

Max. Swing Diameter : 1250 mm  
Max. Turning Diameter : 1100 mm  
Max. Turning Height : 1000 mm  
Max. Load on spindle : 1800 kg  
FANUC Control System : 0iTD

**B . Spindle**

Spindle Nose : A2-15  
Spindle Speed : 20-600 RPM  
Spindle Bearing Diamet : Ø220

**C . Travel Stroke**

X Axis : 700 mm  
Z Axis : 1000 mm

**D . Feedrate**

X Axis Rapid Feedrate : 10 m/min  
Z Axis Rapid Feedrate : 10 m/min

**E . Motor**

Spindle Motor : 37/45 kw (α 40)  
X axis : AC 7.0 KW  
Z axis : AC 7.0 KW

**F . Turret**

Type : Horizontal  
Number of Tools : 12  
Tool Size : □32, ψ60

**G . Coolant System**

Coolant Pressure : 7 Bar (option : 20bar)  
Coolant Tank : 460 liter

**H . Guide Way**

Hardness : HRC 55 (high-frequency induction hardening)  
Thickness of heat treat : 2 - 3 mm  
Width in X axis : 90 mm  
Width in Z axis : 150 mm

**I . Ball Screw Diameter**

X axis : Ø 40 mm, Pitch 12 mm  
Z axis : Ø 50 mm, Pitch 10 mm

**J . Accuracy**

Positioning : 0.001 mm  
Repeatability : 0.005 mm

**K . Power Consumption**

Max loading Requireme : 65 KVA

**L . Machine Size**

Height : 4605 mm  
Floor Space(L\*W) : 4500 x 2520 mm  
Weight : 18000 Kg

**M . Standard Accessories**

Heat Exchanger For Electrical Cabinet  
Oil/Water Separator  
High Pressure Pump  
Chip Conveyer & Chip Cart  
Power Chuck 3 Jaw x 32" + soft jaw (option: 40" chuck)  
Power Chuck with dual pressure  
Hydraulic Unit  
Coolant System  
Auto Lubrication System  
Chamber Lamp  
Hardened & Ground Box ways  
ZF Gear Box for Spindle  
Tool Holder 8 pcs (Power turret doesn't included this)  
Tool collet 5 pcs (Power turret doesn't included this)

- (4.) Power Chuck 3 jaw\*32" upgrade to 3 jaw\*40"
  - (18.) Heidenhain Scale for X Axis
  - (19.) Heidenhain Scale for Z Axis
  - (20.) Chiller for electrical cabinet
  - (21.) CE mark
  - (27.) Transformer
  - (29.) Hard jaw(40" chuck)
- 

#### **Optional Accessories:**

- (1.) Spindle Motor 37/45 kw upgrade to 60/75kw
- (2.) ZF Gear box 2K-300 upgrade to 2K-801
- (3.) Chiller for ZF Gear box 2K 801  
(Option no.1.2.3 need to be selected together)
- (5.) Vertical 6 station Turret
- (6.) BARUFFALDI Power Turret BMT85
- (7.) Coolant through Tool Holder
  - a. Axial Milling Head  
Max.torque 160Nm,3,000rpm/per min
  - b. Radial Drilling and Milling Head  
Torque Max 100Nm,3,000rpm/per min
- (8.) Tool Holder
  - a.Axial Drilling Milling Holder 40. 85501809DW03
  - b.Radial Drilling and Milling Holder 60.85501809V110
  - c.OD Holder 2.25BMT32L90V11(3)
  - d.FACE Holder 5.25BMT32L106V11(3)
  - e.Boring Holder 17.25BMT60X110V11(1)
- (9.) Auto Door
- (10.) Side door open capability(Manual)
- (11.) Crane preparation without motor
- (12.) Electric crane
- (13.) Oil mist filter
- (14.) Scraper type of chip conveyor
- (15.) Filter of coolant water
- (16.) Metal frame and case in machine shipment packing  
(only bottom is metal, other pack with wooden case)
- (17.) Tool setter probing system
- (22.) Screen 8.4" up 10.4" TFT Color Display
- (23.) Manual Guide Oi upgrade to Manual Guide I
- (24.) Fanuc OiTD -->32iTB
- (25.) Fanuc OiTD --> Siemens 828
- (26.) Gear Box (1:3) for X,Z AC Motor ( 30Nm up to 90Nm)
- (28.) Soft Jaw
- (30.) Machine guard Enlarge to Max.swing 1300mm
- (31.) Coolant High Pressure Pump (Pressure 20 bar, 30L/ Min)

**Remark:**

- (1.) The above price excluded Installation & Trial- run in Buyer's factory, Air round-trip ticket, Local transportation, Hotel, and Meal expense as well as Daily Engineer's Salary/day/person at customer's account.
- (2.) The cutting tools and fixtures / jigs are not included in this quotation.
- (3.) Warranty:
  - A- All our mechanical parts, system and AC Motors are one year free Guarantee.
  - B- FANUC control system is free Guarantee within two years after Machine on approval in buyer site.
  - C- We Guarantee our machines will have stable and superior performance under you follow the regular operating and maintenance schedule of the manual.
  - D- Any damages caused by the Nature Disaster are out of our Guarantee.
- (4.) In respect of International Wassenaar Arrangement do not allow any Dual-Use Goods & Equipments be used in Weapons of Mass Destruction & prevent the Weapons Proliferation. All machines of Yu Shine prohibited to be re-sold to the countries of Iran, North Korea, Cuba & Syria. Your company should bear full responsibility for the errors and negligence if you was in violation of Wassenaar Arrangement

## Standard Specification

### 1. Capacity



### 2. Turret System

Turret Type : Horizontal  
 Number of T: 12  
 Tool Size : □32, ψ60  
 Tool Holder : 8  
 Tool Collet : 5  
 Power Chuck : 32"

### 3. Axis Travel Diagram

#### Axis Travel Diagram

Unit: mm

##### Single Type

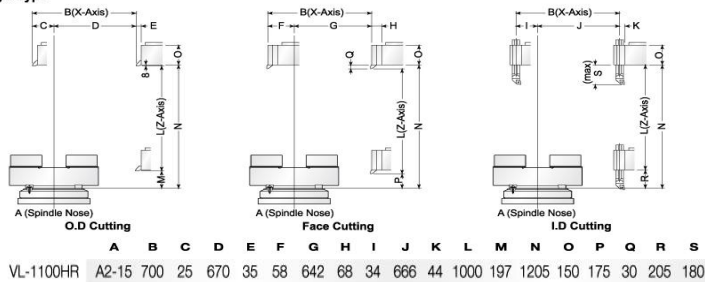

#### 4. Tool Interference

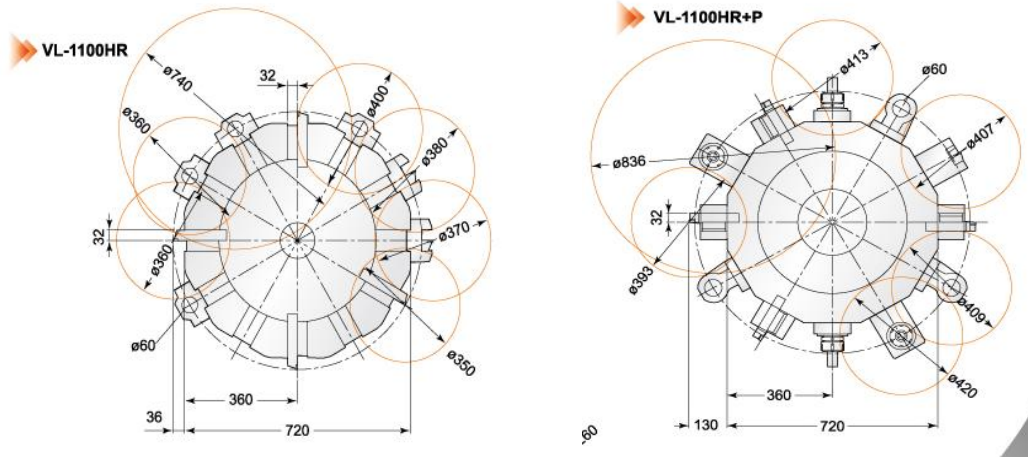

#### 5. Motor

Spindle Motor : 37/45 kw  
 X axis : AC 7.0 KW  
 Z axis : AC 7.0 KW

#### VL-1100 H Series Standard-Gear Box

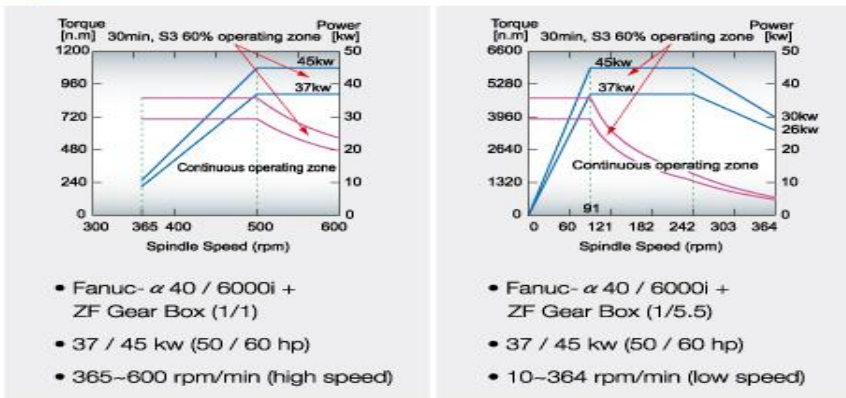

## 6. Machine Size

### Machine Dimensions

Unit: mm

#### Single Type

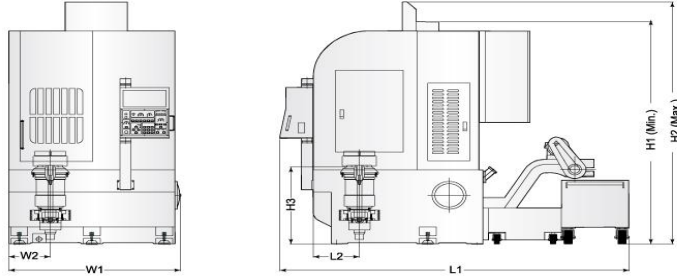

	L1	L2	W1	W2	H1	H2	H3
VL-350R Series	2900	310	1500	270	2250	2700	950
VL-450R Series	3000	360	1510	320	2350	2800	970
VL-600HR Series	3100	410	1510	370	2600	3030	1020
VL-750HR Series	3400	500	1780	425	3130	3855	1120
VL-850HR Series	4285	600	2300	535	3220	4020	1226
VL-1000HR Series	4285	750	2900	735	3220	4020	1226
VL-1100HR Series	4500	726	2520	700	3725	4605	1322

## 7. Machine Foundation

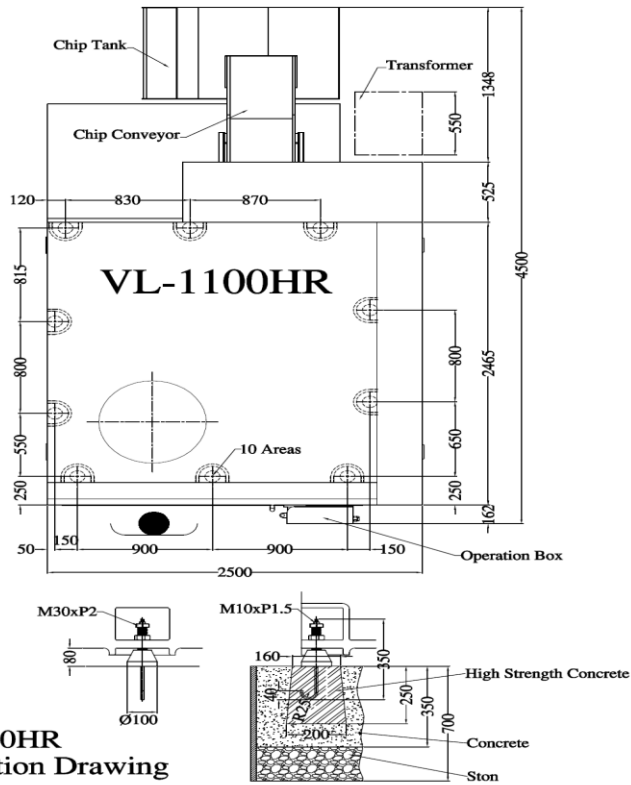

YU SHINE PRECISION MACHINE CO.,LTD

## 8. Machine Size

Machine L \* V 4500 \* 2520 mm

Machine H 4605 mm

Machine Weight 18000 kg

Power Required 65 kva

**HOTLINE: +49-6158-84772**  
**info@gk-werkzeugmaschinen.de**