



WERKZEUGMASCHINEN GMBH

5 BED WAY HEAVY DUTY CNC LATHE

LL Series

5 BED WAY HEAVY DUTY CNC LATHE

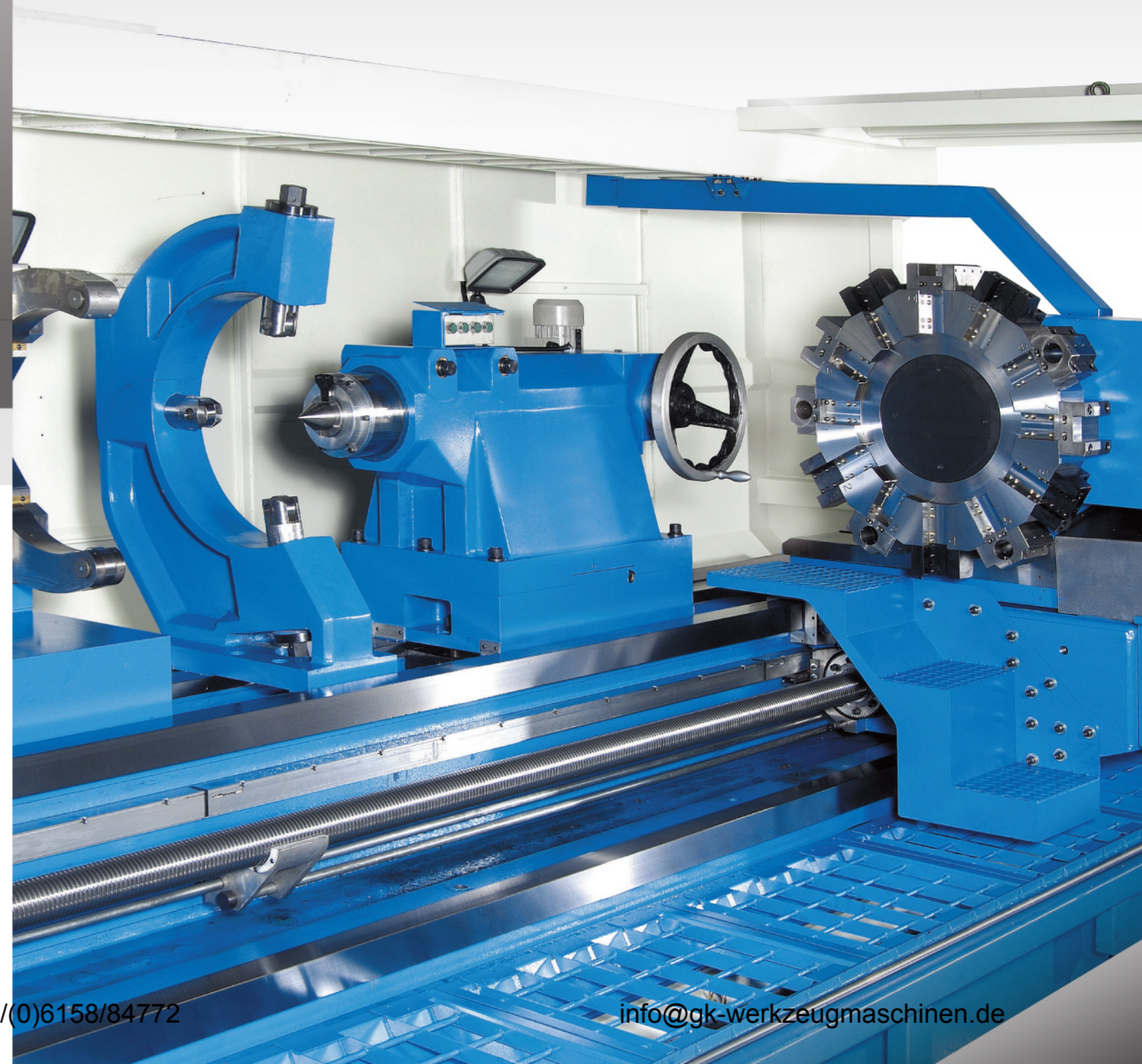

WERKZEUGMASCHINEN GMBH

HOTLINE: +49-6158-84772
info@gk-werkzeugmaschinen.de

15064_1000_03_102.E

DESIGNED CONCEPT ◀

- The new model, “LL” series is designed to combine more advantages and revolutionize large CNC lathes.
- For large and long work pieces, steady rests have to support the work piece. However, this creates serious interference with the carriage for current flat bed lathes.
- Slant bed lathes can work without interference between bed and steady rest, but can not support large and long work pieces.
- Especially ideal for turning long shafts and hollow tubes, it overcomes the interference between the carriage and steady rest completely.
- In order to integrate the rigidity of a “flat bed lathe” with the advantages of a “slant bed lathe”, we have created a brand new construction: the 5 bed way, heavy duty CNC lathe LL series.
- The LL series is also equipped with C axis, rotating around Z axis, designed based on control of spindle servo motor. Collocating Heidenhain Modular Magnetic Encoder, reaching the aim of precise positioning. Thus, C axis is equal to the fourth axis of a milling machine, working with servo spindle. A CNC lathe equipped C axis together with live tooling, can process basic boring and milling.
- The LL series integrates the advantages of “super rigidity”, “high efficiency” and “perfect accuracy” in one machine.

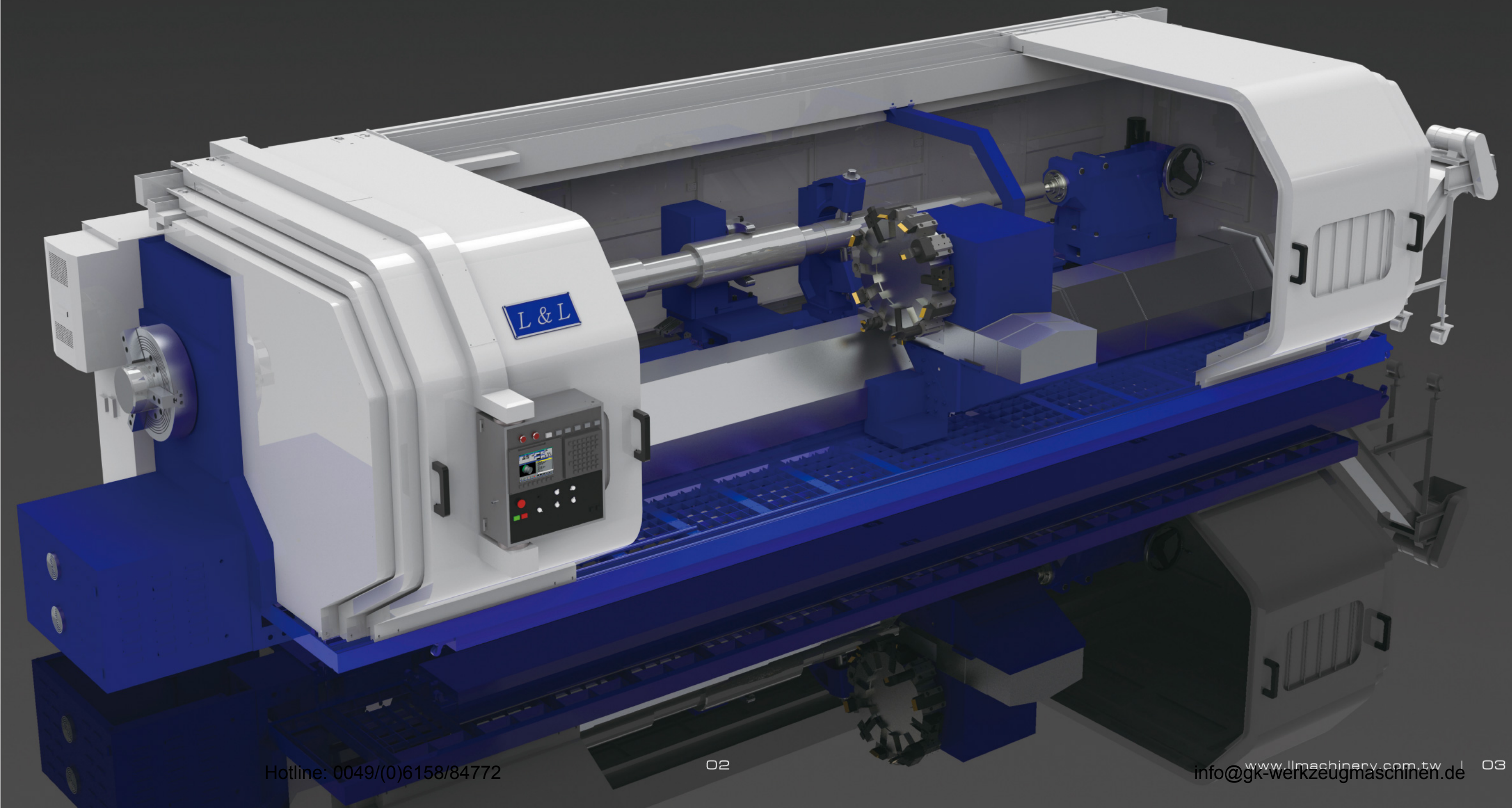

5 BED WAY HEAVY DUTY CNC lathe

Let L&L's outstanding experience work for you



◀ LL 950

ADVANTAGES - LL Series

- As rigid as a " flat bed lathe ", As efficient as a " slant bed "
- No interference
- Compact to save space
- Economic
- Larger working capacity

LL 750 X 3000 - 8000

LL 950 X 3000 - 10000

- Maximum cutting diameter
- Between centers
- Bed width
- Spindle bore
- Turret
- Tailstock quill diameter

LL750

750 mm
3000-8000 mm
990 mm
153 / 230 / 305 mm
V8-160
165 mm

LL950

950 mm
3000-10000 mm
990 mm
153 / 230 / 305 / 405 mm
V12-200
200 mm

Double chuck, C-axis, Milling function are all available for LL750 and LL950

LL 750 ▶



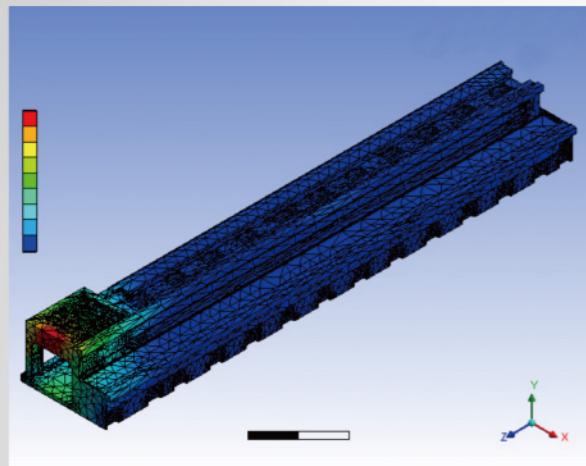

Bed construction analysis

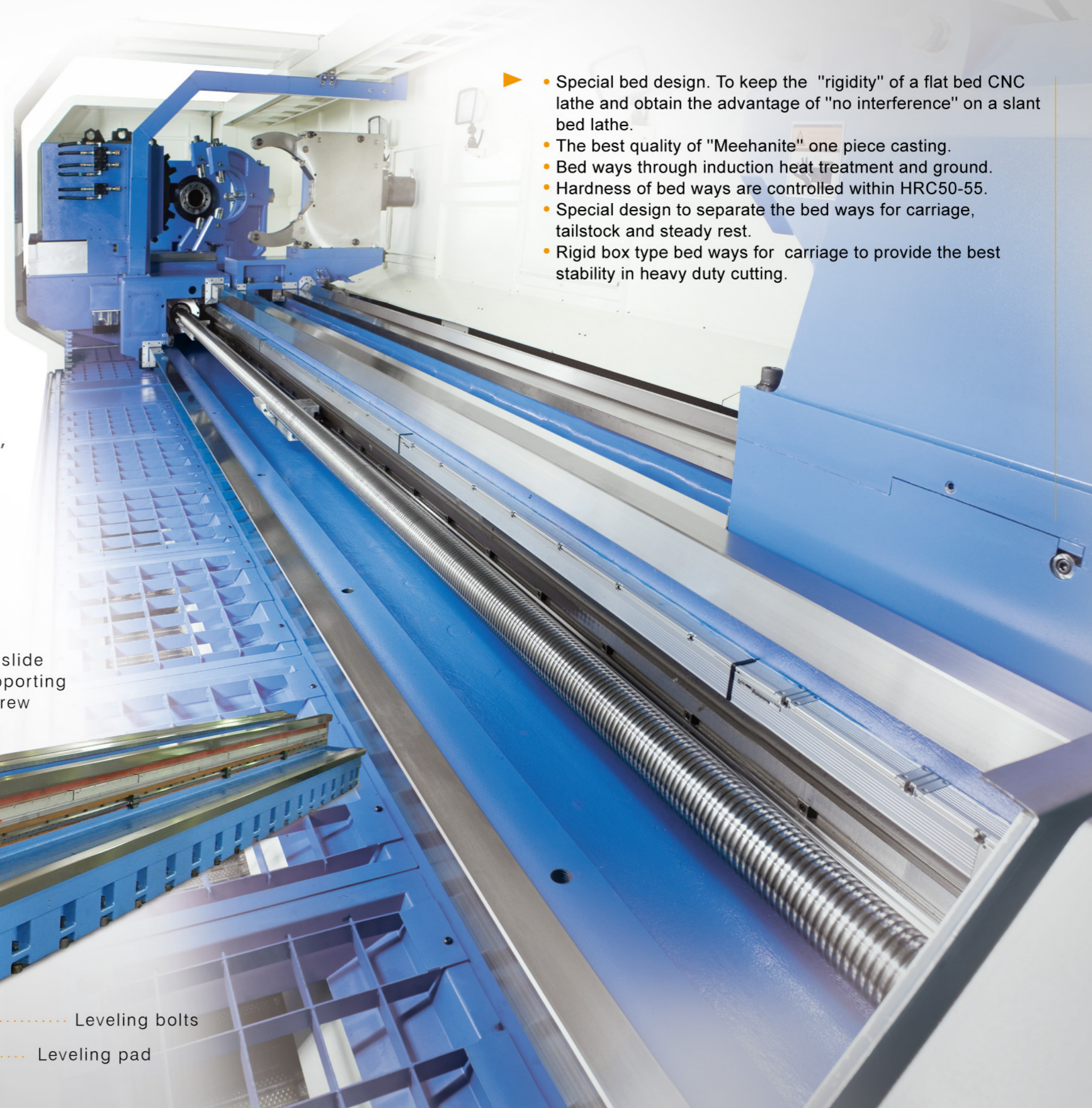

- ▶ Special bed design. To keep the "rigidity" of a flat bed CNC lathe and obtain the advantage of "no interference" on a slant bed lathe.
- ▶ The best quality of "Meehanite" one piece casting.
- ▶ Bed ways through induction heat treatment and ground.
- ▶ Hardness of bed ways are controlled within HRC50-55.
- ▶ Special design to separate the bed ways for carriage, tailstock and steady rest.
- ▶ Rigid box type bed ways for carriage to provide the best stability in heavy duty cutting.

BED



One piece Meehanite bed, rigid with high accuracy

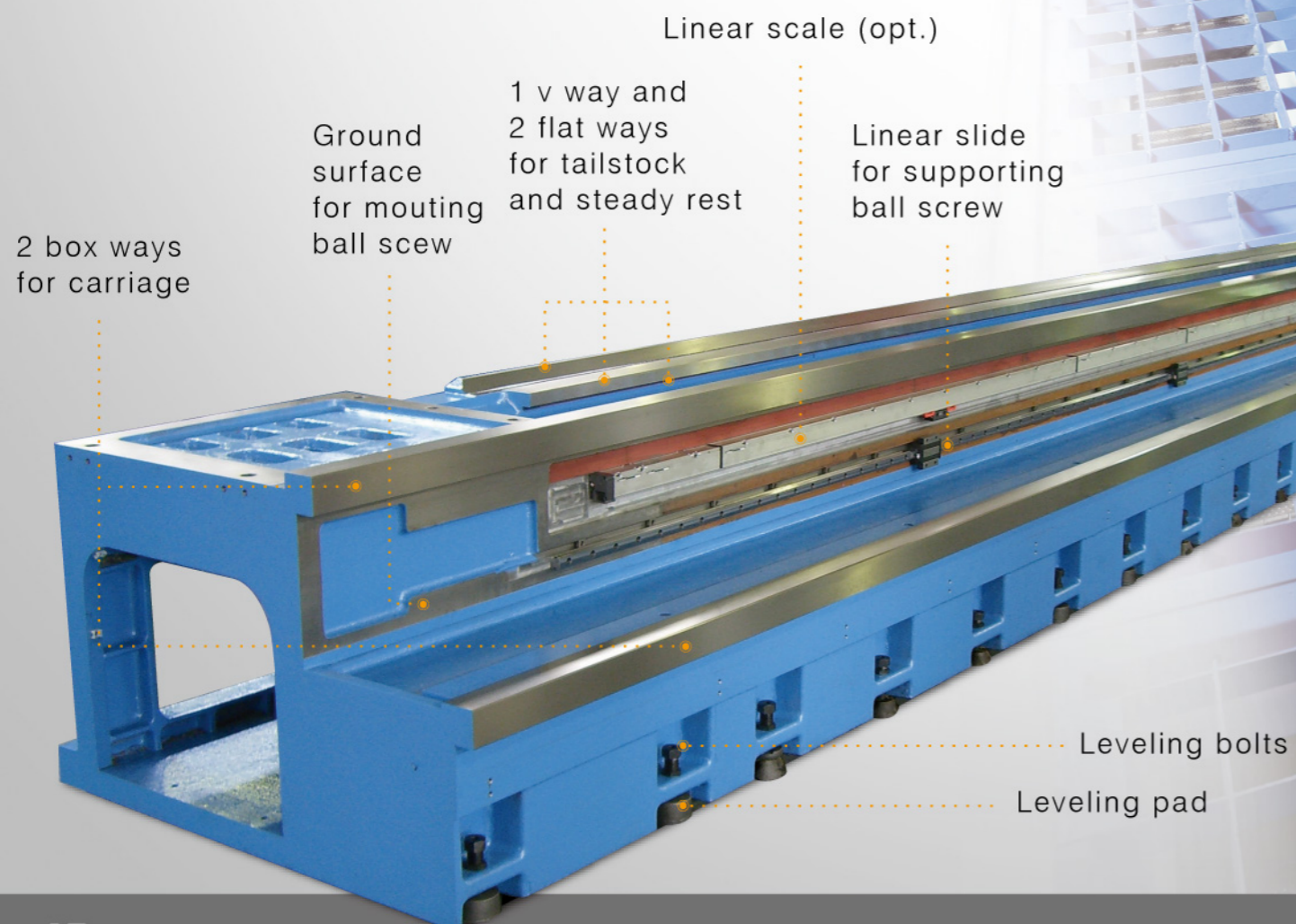

▶ NO COMPROMISE
ON QUALITY ▲

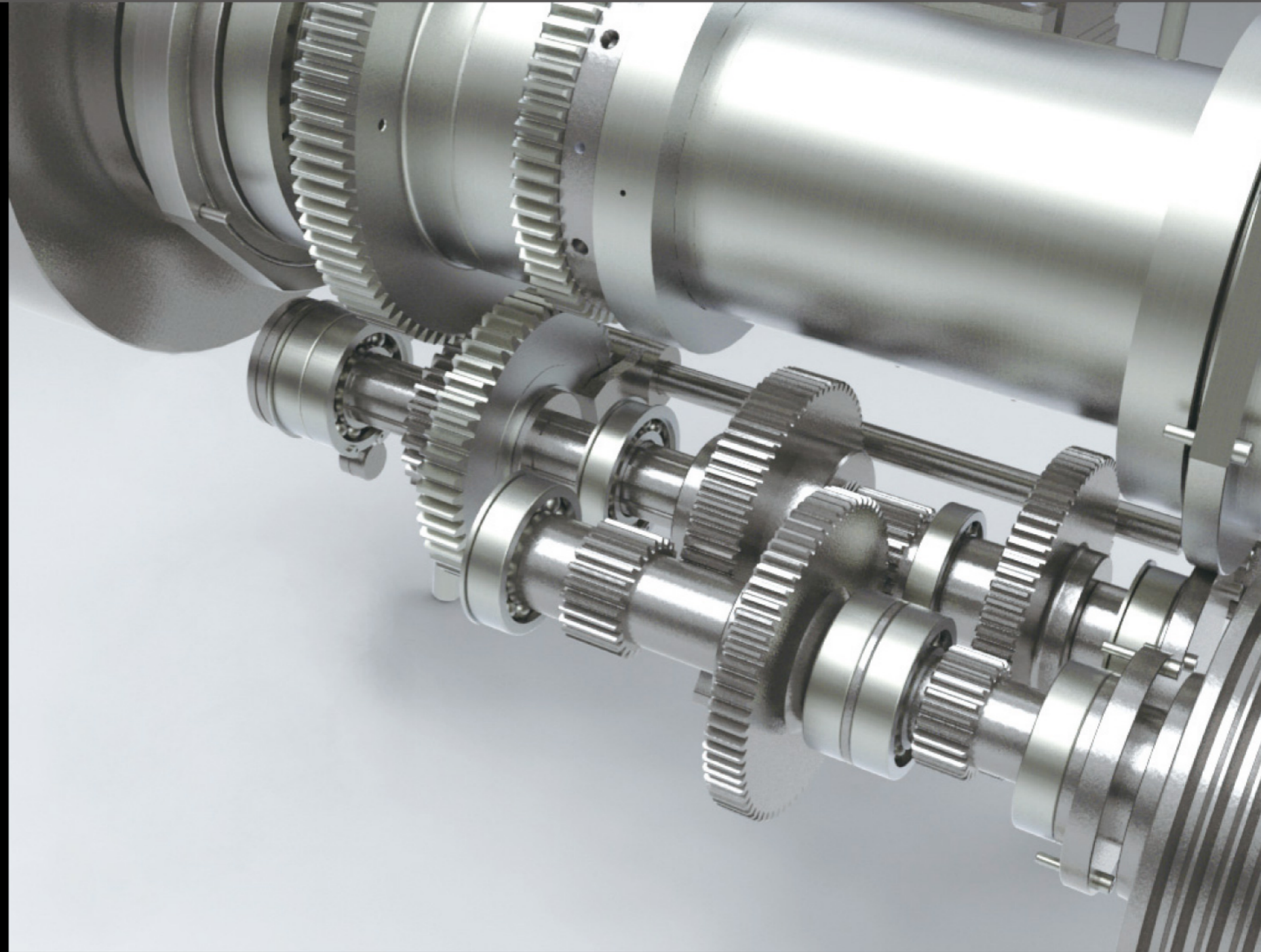

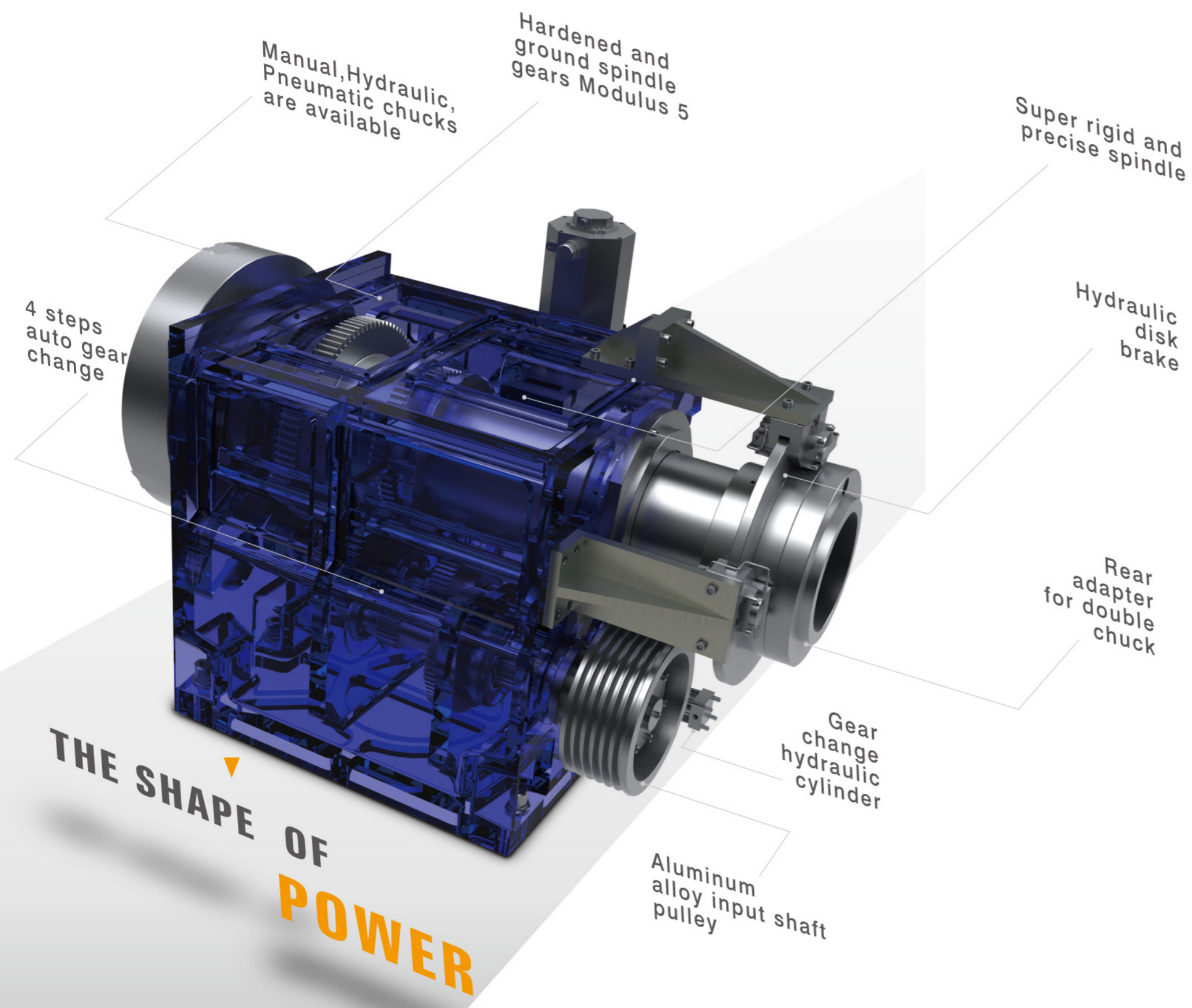

HEADSTOCK ◀

- The solid box-construction casting provides excellent rigidity for heavy cutting.
- All gears in headstock are hardened and precisely ground.
- The spindle is supported by high precision taper roller bearings.
- Spindle speed ranges are automatically changed by M code.
- Infinitely variable speeds are commanded by S code.
- An auto-lubrication system is equipped for headstock gears and spindle.
- Double chucks strengthen the stability for turning a long work piece through spindle.

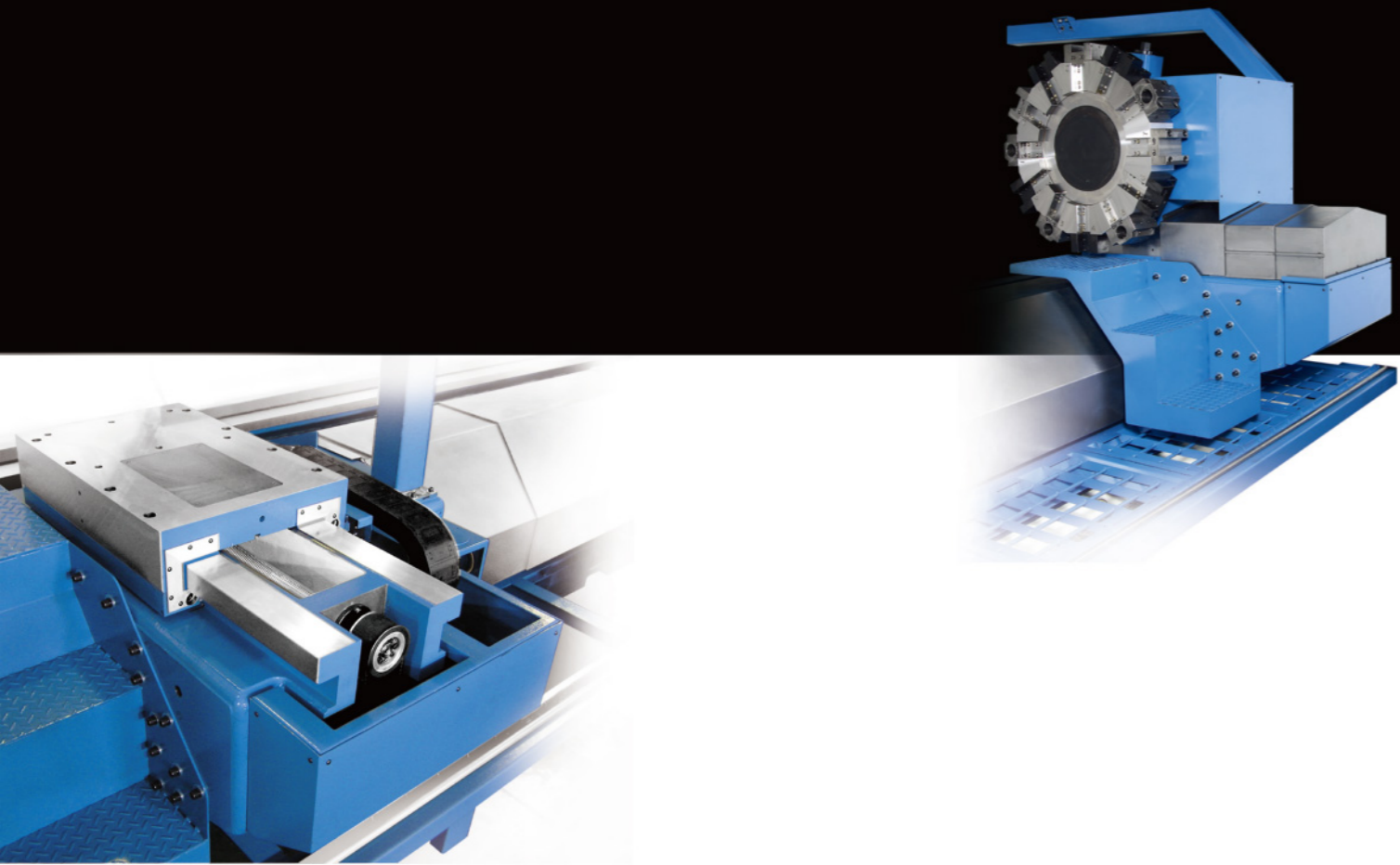

CARRIAGE, CROSS SLIDE AND TURRET

LL950: V12-200 turret
Disk diameter: 660 mm

- ▶ No interference between carriage and steady rest.
- ▶ "Box type" carriage and cross slide.
- ▶ Turcite B lining is applied on cross slide and carriage to reduce friction.
- ▶ Heavy duty boring bar is available to install and programmable on sub saddle.
- ▶ V-8 / V-12 vertical 8/12-position large size hydraulic turret is standard.
- ▶ Hidden conduit design, to avoid damage from coolant and chips.

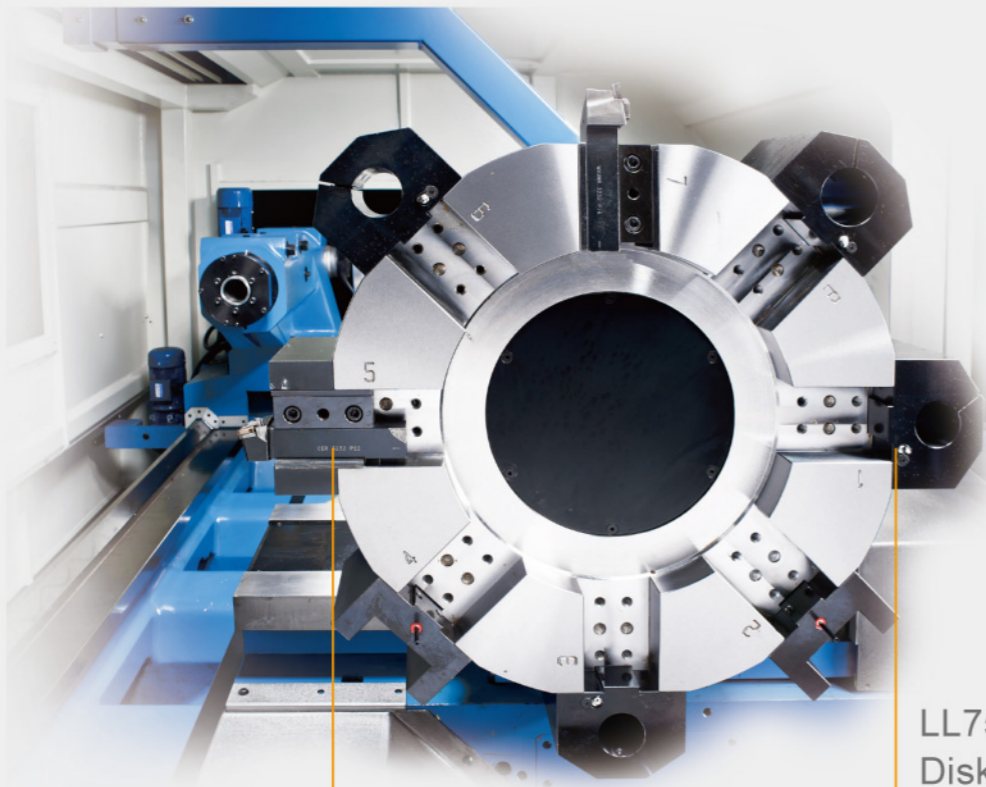
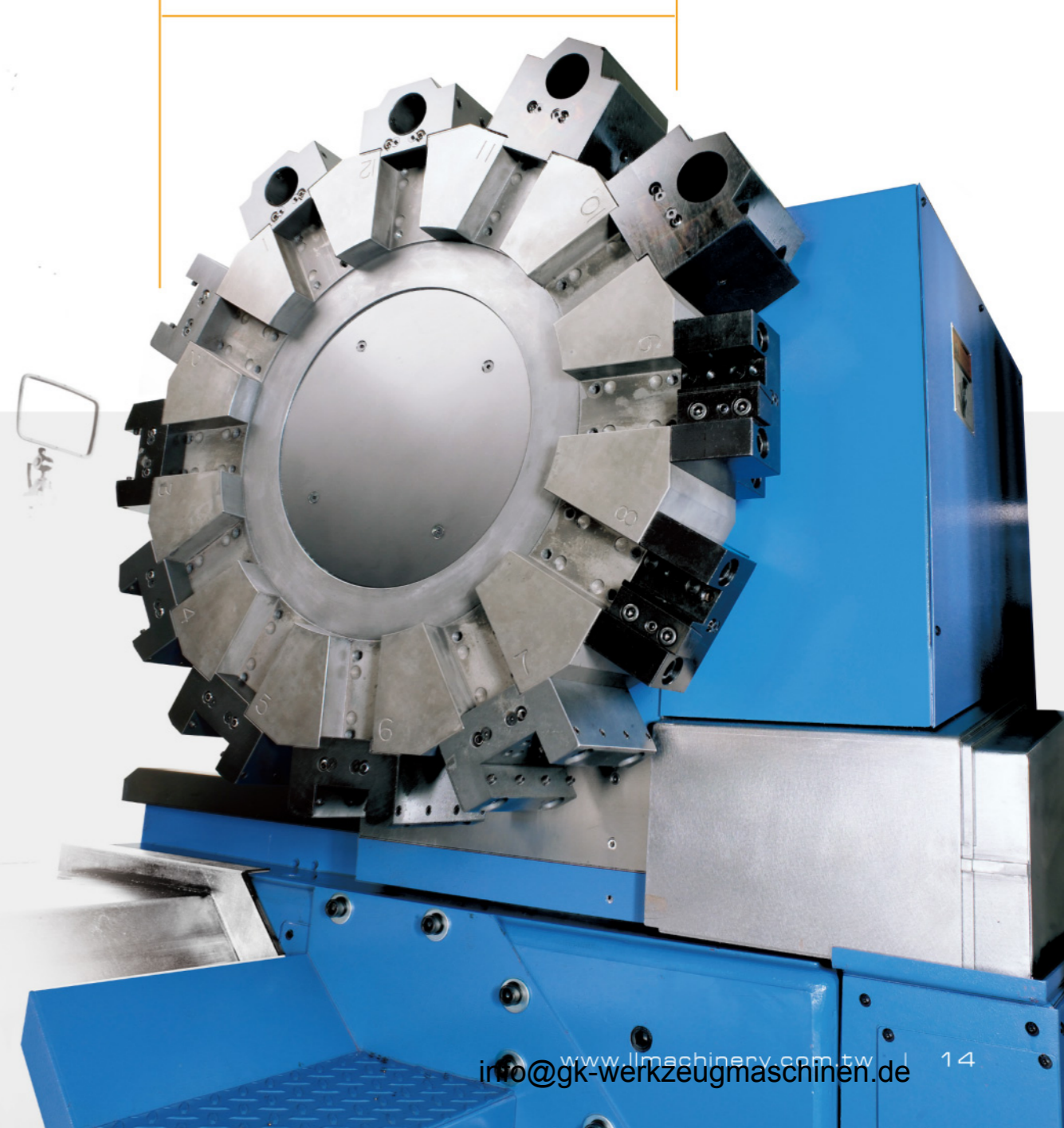

LL750: V8-160 turret
Disk diameter: 580 mm

Heavy duty
taper roller
bearings

Tailstock quill
motorized move

Spherical
roller thrust
bearing

Angular ball
bearing

Tailstock quill
handwheel

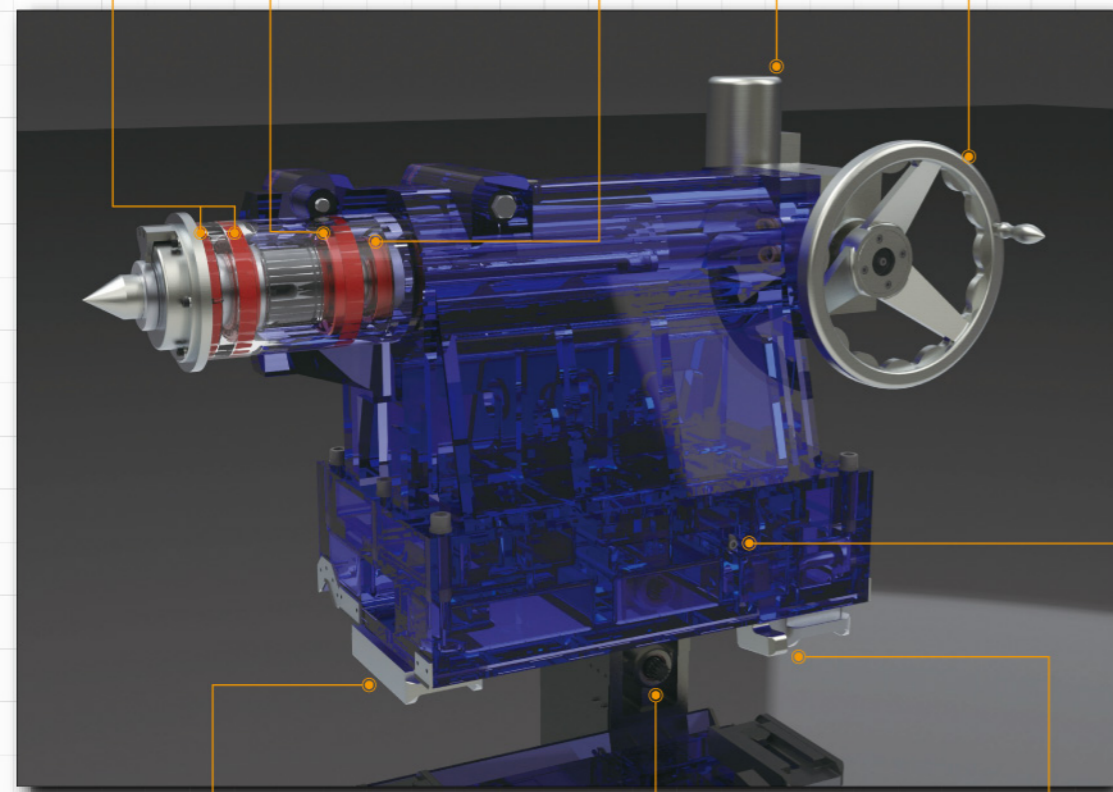

Tailstock body
clamping base

Tailstock body
motorized
movement

Safety hook
to prevent
movement

Position
adjusting
bolts

LL750: 165 mm
LL950: 200 mm

FEATURES

- Super rigid supporting power.
- Quill diameter LL750: 165 mm / LL950: 200 mm.
- 2 heavy duty taper roller bearings, 1 Spherical roller thrust bearing and 1 angular ball bearing are installed.
- Rotating quill.
- MT#6 dead center or live center are available.
- Electric and manual quill movement.
- Motorized body movement.
- Hydraulic quill movement: optional
- Hydraulic body clamping: optional

TAILSTOCK ▼
Extraordinary support

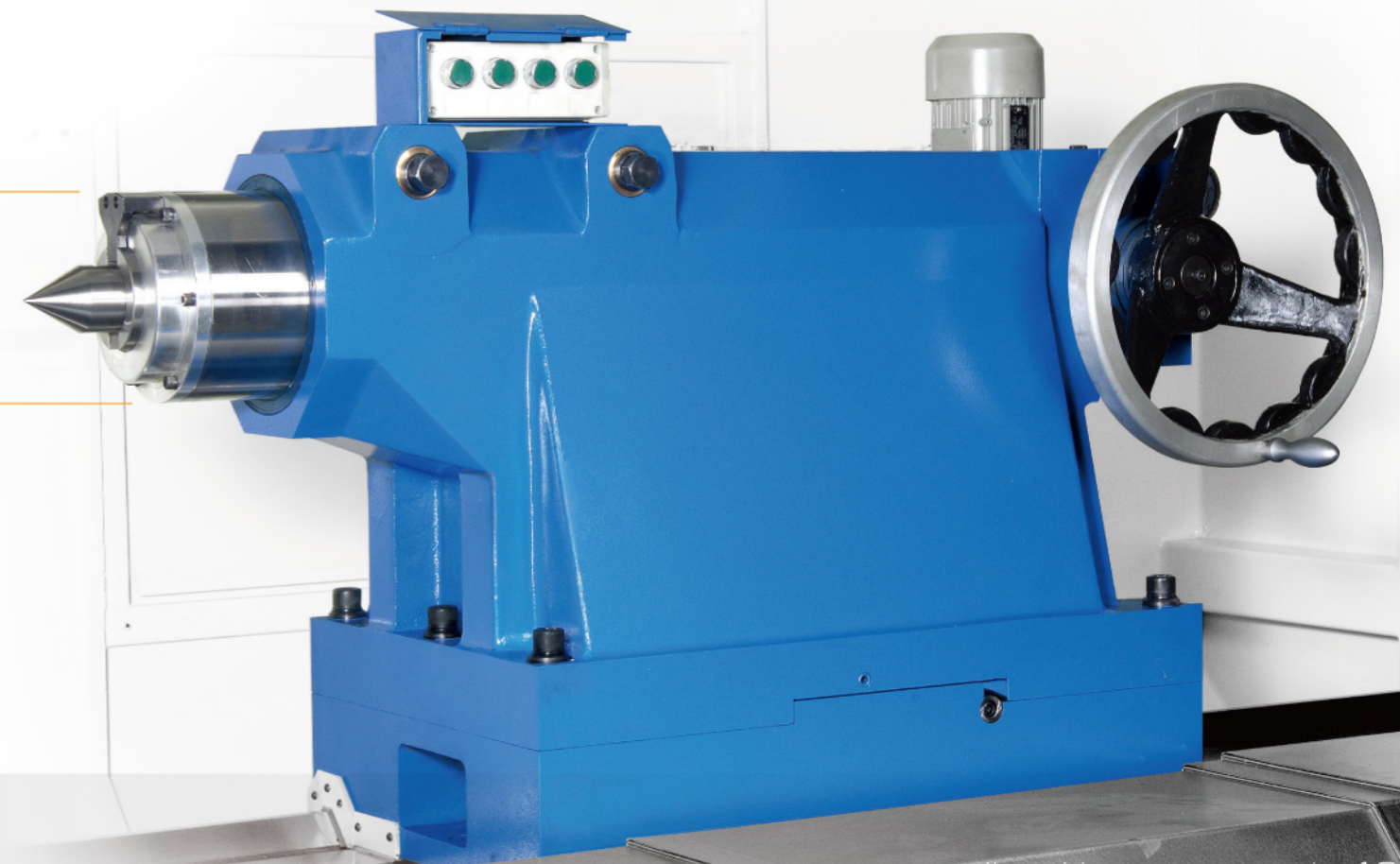

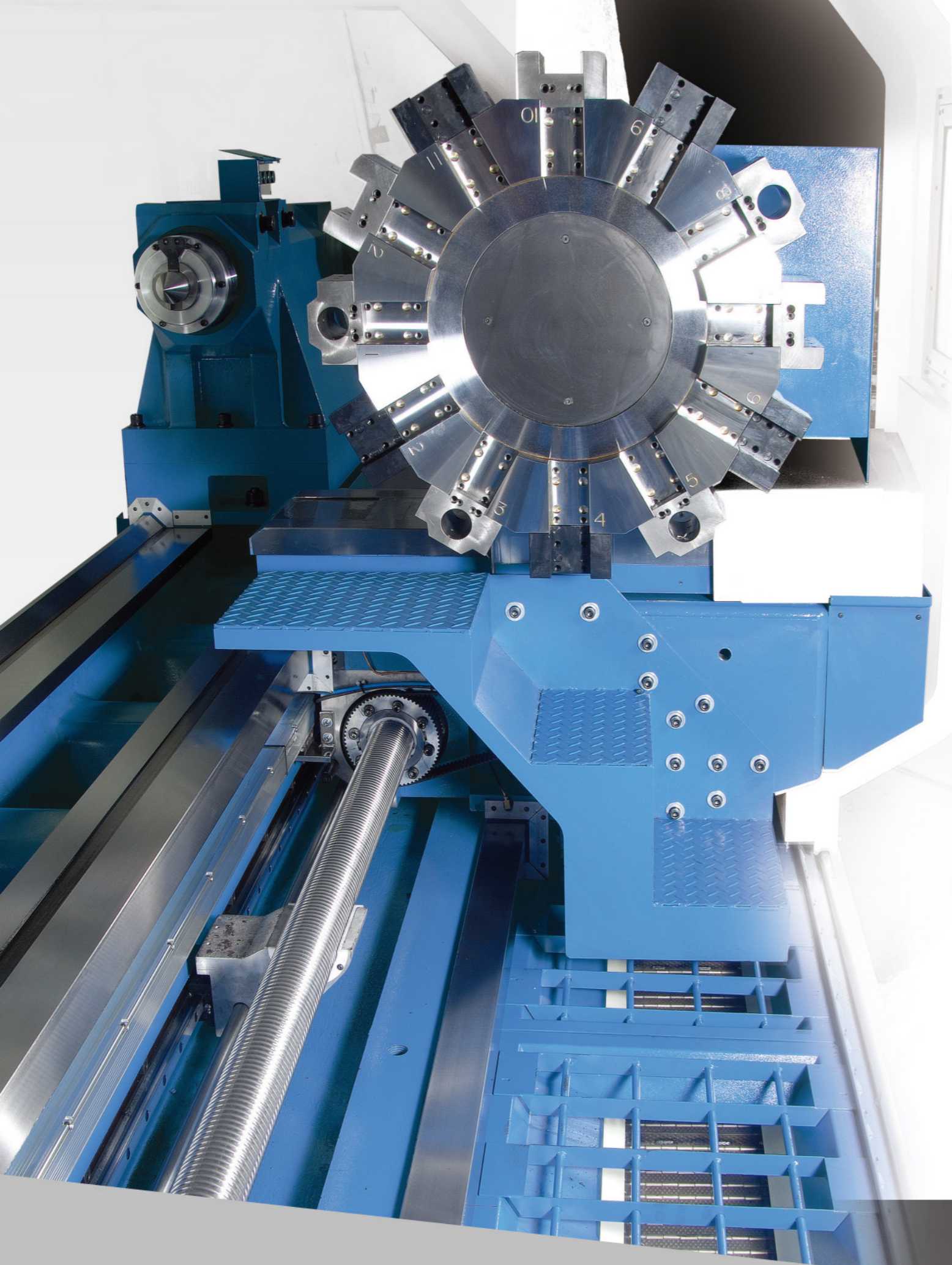

TRANSMITTING SYSTEM ◀

■ No drifting of carriage

Z-axis ball screw is installed in the center of two box type beds ways.

■ Torque increase

Z-axis servo motor transmits power through 1:2 timing belt to increase torque.

■ No vibration

- 3-5M: Ball screw rotating (through 1:4 planetary gear reducer)
- 6-10M: Nut rotating (through precise helical gear)

■ High accuracy

This system prevents vibration of long ball screw, increasing position accuracy and reducing noise.

■ No chip damage

Z-axis ball screw is protected by fully enclosed telescopic cover.

■ Durable

Ball screw is supported by linear slide. To make sure of the linearity, there is no bending or vibration of long ball screw.

CHIP REMOVAL

- ▶ • Front and rear chip conveyors
- High pressure coolant pump

CNC CONTROLLER ◀

Full line of high quality CNC lathes to meet your turning challenges.

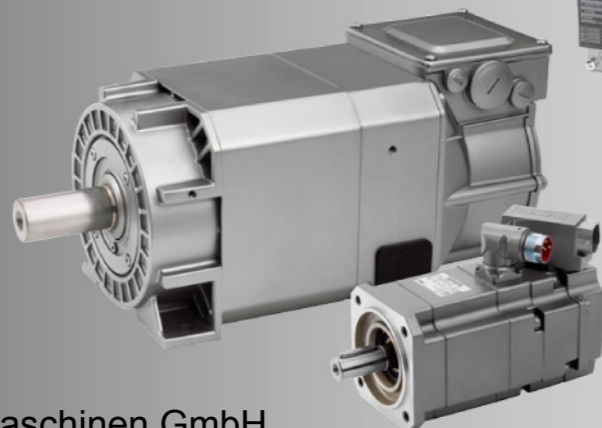
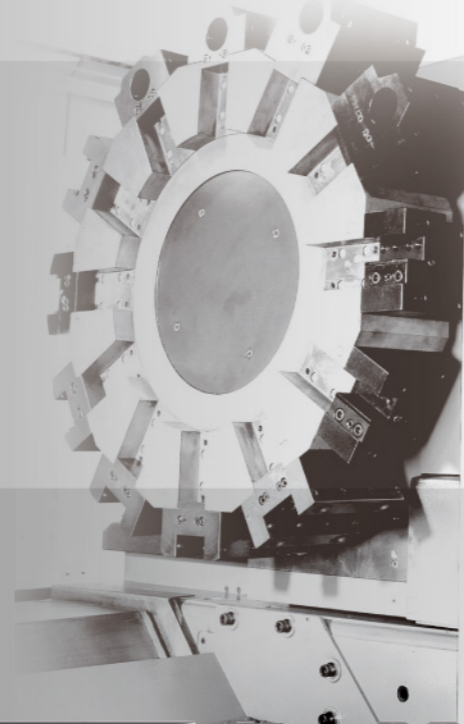

▶ STD: FANUC Oi-TD

- 10.4" TFT-LCD color screen
- "Manual guide i" conversational system optional
- Powerful built-in PMC
- Variety of display units
- User friendly operation
 - 3D dynamic graphic display
 - Help function
 - Alarm history / operation history
- Simple operation programming support tool
- Thread repair function

OPT: SIEMENS 828D

- High-performance panel-based CNC control
- Robust panel front made of die-cast magnesium
- 10.4" color TFT display
- Maintenance-free design (no buffer battery required)
- 4-axes simultaneous interpolation(X,Y,Z rotary axis)
- 100 programmable work piece zero offsets
- Built-in ISO code interpreter
- Wide range of turning cycles for standard geometries
- Graphic CNC simulation plane display
- All-in-one tool and magazine data
- Extension of CNC memory by user CF-card on panel front

CHUCK ◀

- Manual, hydraulic, pneumatic chuck are available.
- Second chuck can be mounted on spindle rear adapter.
- Jog button for mounting chuck easily.

▶ HYDRAULIC STEADY REST

- Clamping different diameter work piece auto adjustment
- High concentricity
- Saves time
- Motorized body movement
- Clamping and unclamping controled by M code

MANUAL STEADY REST ▶

- Ø80mm quill
- Three point heavy duty needle roller bearing.
- Tool can pass steady rest without interference.
- Capacity : 100-300mm, 300-500mm, 500-750 mm

BORING ATTACHMENT AND SUB CARRIAGE.

Milling attachment is available to be mounted on sub-carriage.

- Including boring bar and boring bar support. Installed on cross slide, the boring depth and diameter can be controlled by program.
- Depending on client requirements, boring sleeve can also be added.

KEEP IMPROVING FOR EXCEPTIONAL SATISFACTION

Special designs to overcome different machining challenges

[**Power Utilities**]

[**Aerospace**]

[**Oil & Gas**]

[**Marine**]

[**Steel Utilities**]



UNBEATABLE CUTTING ABILITY ▼

APPLICATION IN INDUSTRIES

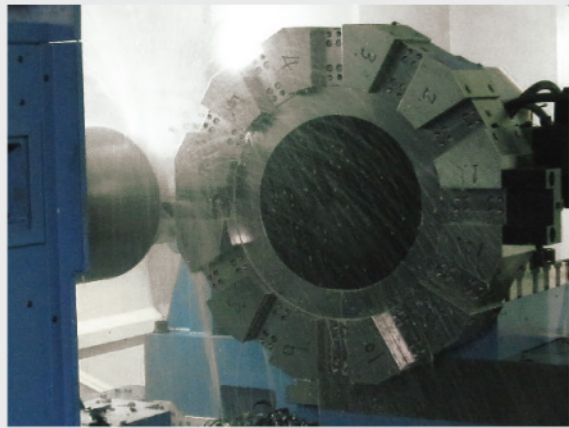

Heavy Cutting



Deep Hole Boring



Oil & Gas Industry

Object: Oil & Gas Pipe

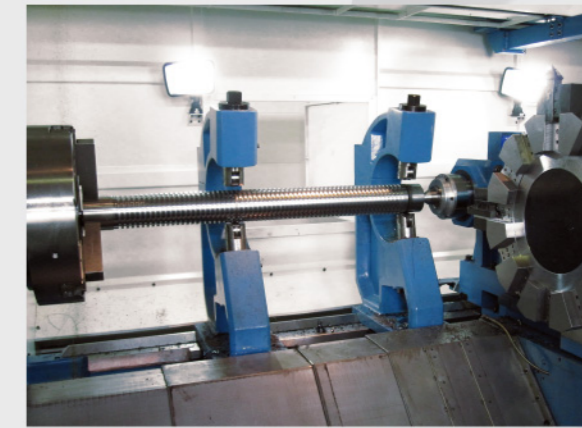

Plastic Industry

Object: Tie Bar & Screw



Drilling

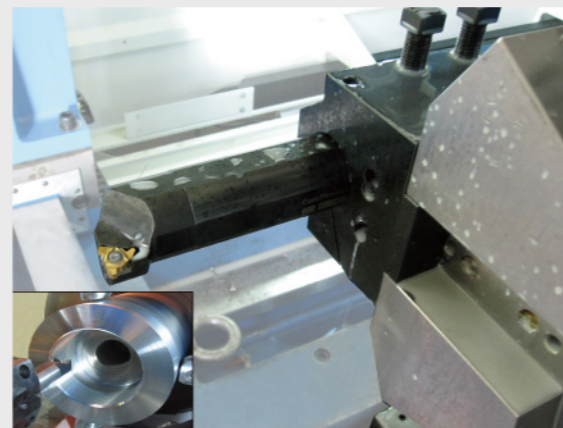

API Threading

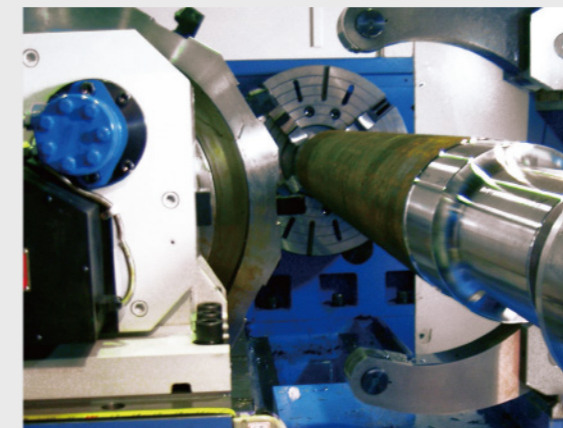

Energy Industry

Object: Wind Turbine Shaft



Hydraulic Industry

Object: Cylinder & Piston

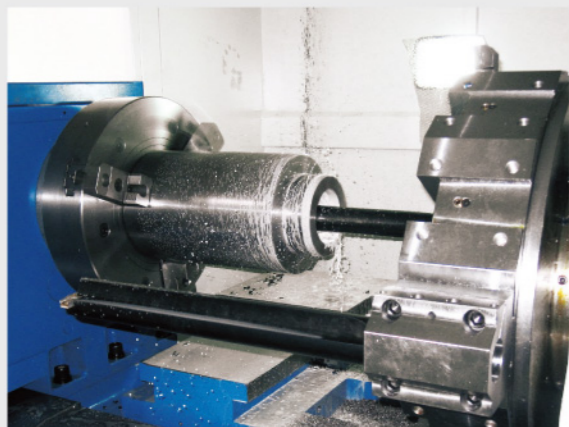

Boring

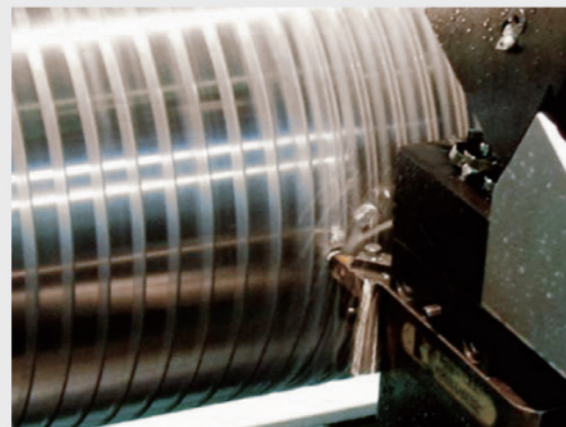

Grooving



Marine

Object: Transmission Shaft



Nuclear Industry

Object: Fuel Rod

LOADING CAPACITY ▼

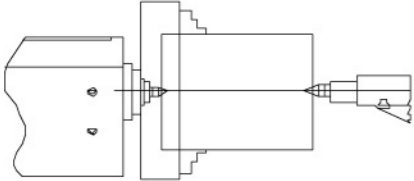
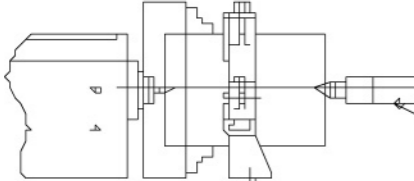
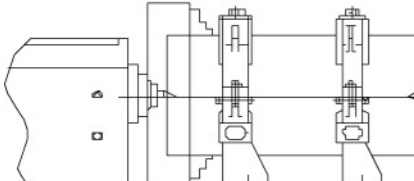
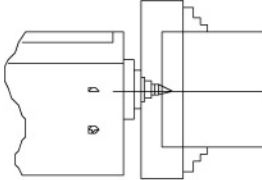
Model	LL750			LL950		
Spindle bore	6" A2-11	9" A2-15	12" A2-20	6" A2-11	9" A2-15	12" A2-20
Tailstock quill diameter	165 mm	165 mm	165 mm	200 mm	200 mm	200 mm
Max. load between centers						
	6000 kgs	7000 kgs	8000 kgs	7000 kgs	8000 kgs	9000 kgs
Max. load between centers plus 1 steady rest						
	7000 kgs	8000 kgs	9000 kgs	8000 kgs	9000 kgs	10000 kgs
Max. load between centers plus 2 steady rest						
	8888 kgs	9000 kgs	10000 kgs	9000 kgs	10000 kgs	11000 kgs
Max. load with one chuck only						
	2000 kgs	2200 kgs	2400 kgs	2200 kgs	2400 kgs	2600 kgs

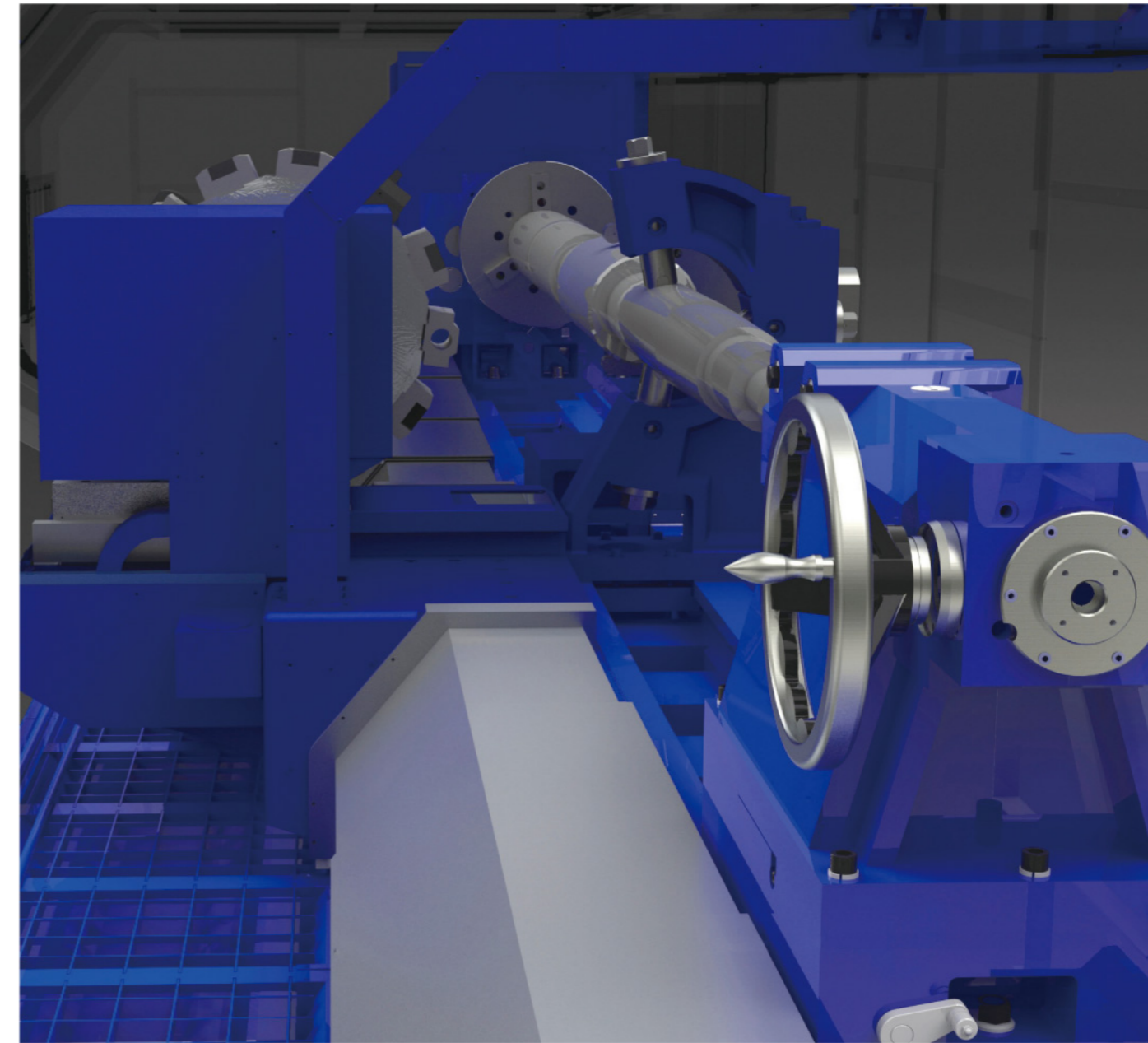

NO CUTTING INTERFERENCE



INTERFERENCE DRAWINGS ▼

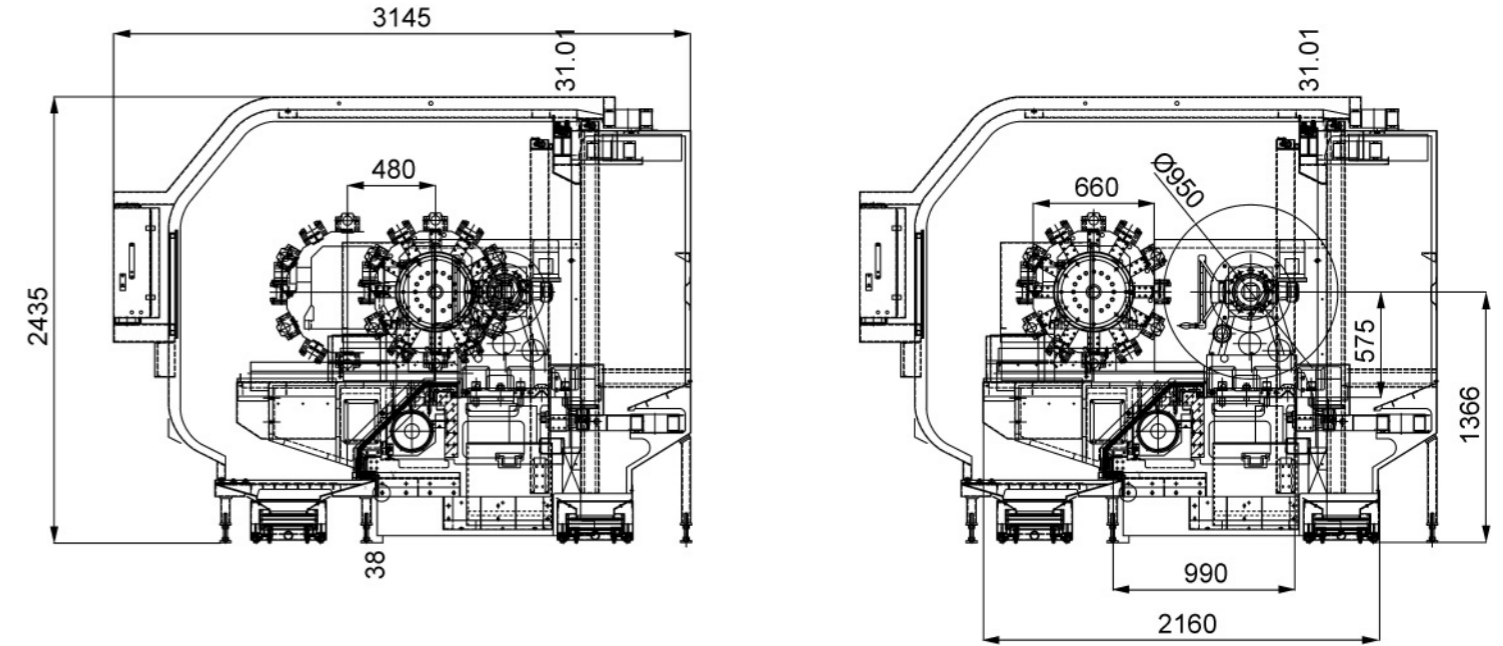
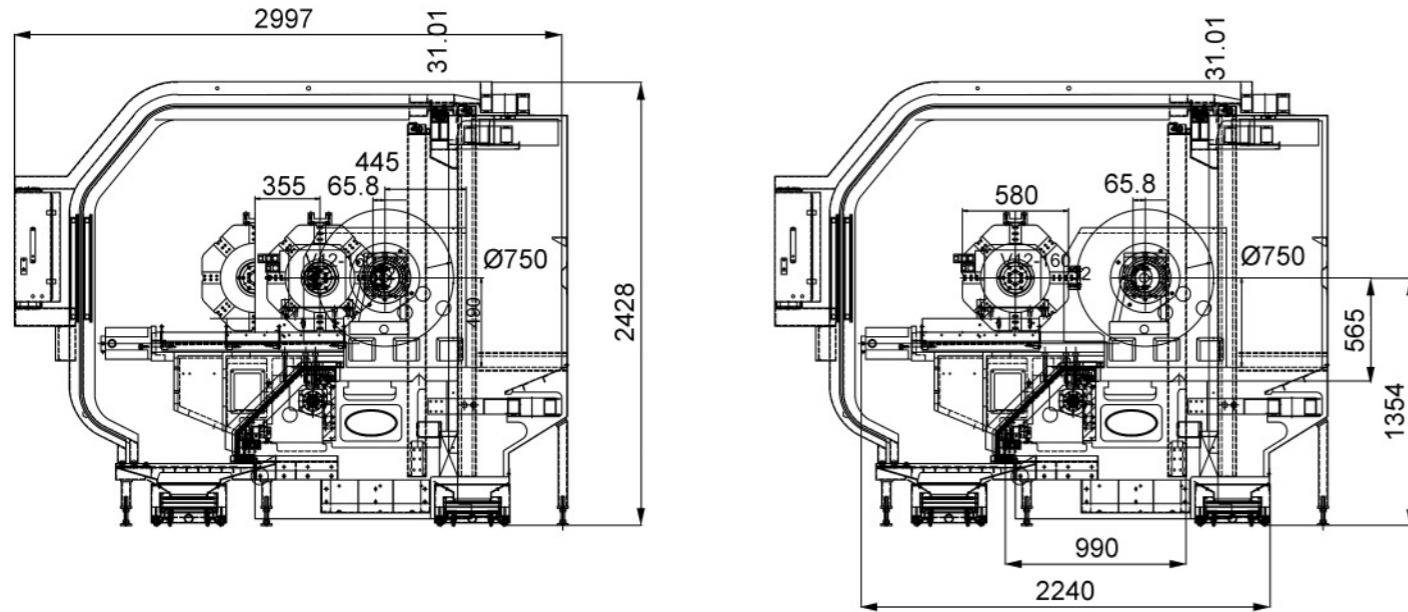

DIMENSIONAL DRAWINGS

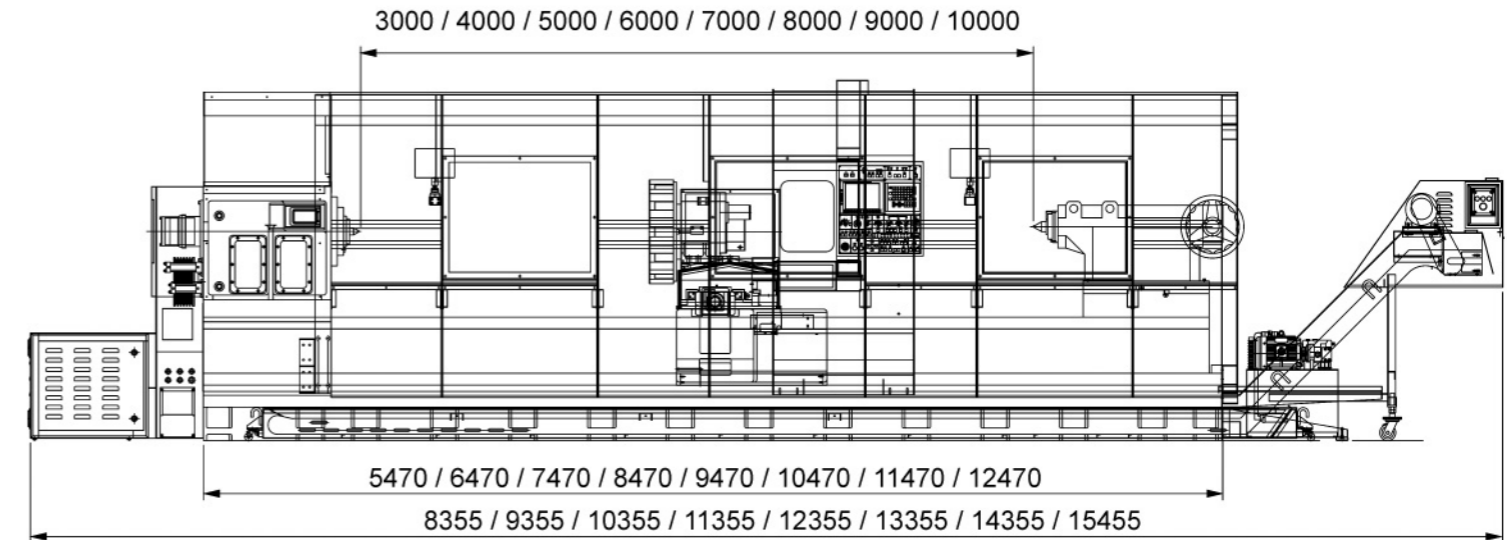
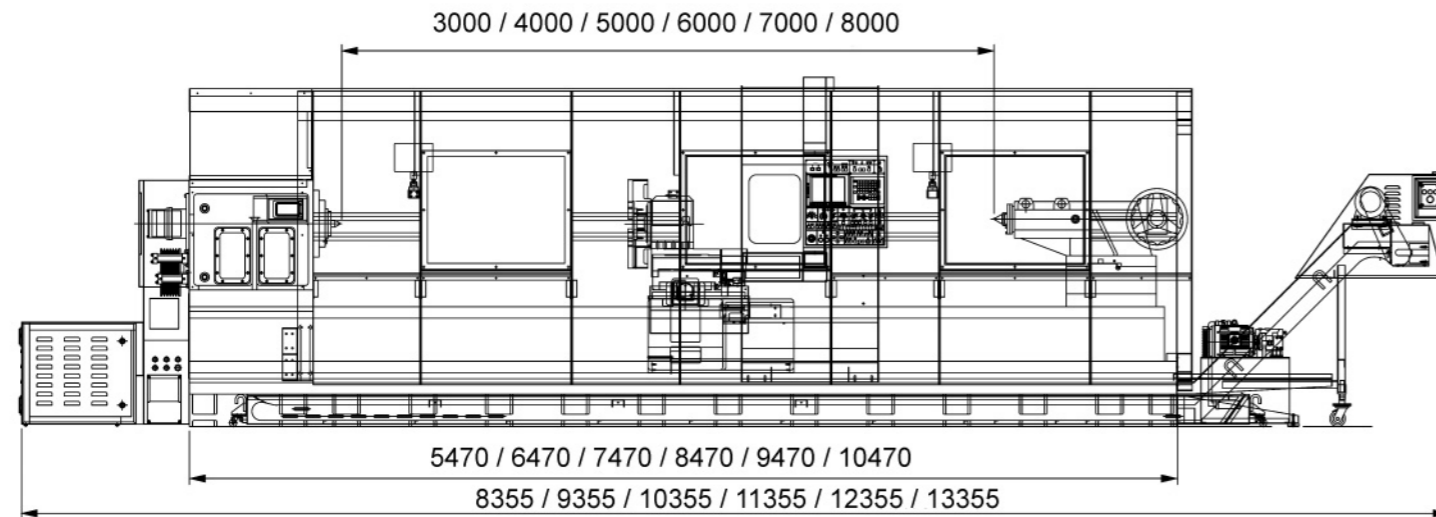

MACHINE DIMENSIONS AND WEIGHT ◀

LL750 series	BC 3000 mm	BC 4000 mm	BC 5000 mm	BC 6000 mm	BC 7000 mm	BC 8000 mm
L x W x H (mm)	5470 x 3250 x 2370	6470 x 3250 x 2370	7470 x 3250 x 2370	8470 x 3250 x 2370	9470 x 3250 x 2370	10470 x 3250 x 2370
N.W / G.W	12,700 / 13,770 kg	15,370 / 16,070 kg	18,040 / 18,370 kg	21,500 / 23,100 kg	24,080 / 25,850 kg	26,660 / 28,160 kg

LL950 series	BC 3000 mm	BC 4000 mm	BC 5000 mm	BC 6000 mm	BC 7000 mm	BC 8000 mm	BC 9000 mm	BC 10000 mm
L x W x H (mm)	5470 x 3450 x 2370	6470 x 3450 x 2370	7470 x 3450 x 2370	8470 x 3450 x 2370	9470 x 3450 x 2370	10470 x 3450 x 2370	11470 x 3450 x 2370	12470 x 3450 x 2370
N.W / G.W	13,700 / 14,770 kg	16,370 / 17,070 kg	19,040 / 19,370 kg	22,250 / 24,100 kg	25,080 / 26,850 kg	27,660 / 29,160 kg	30,260 / 32,260 kg	32,950 / 34,100 kg

SPECIFICATIONS ◀

Model	LL-750	LL-950		
Maximum Cutting Diameter	750 mm	950 mm		
Center Height	490 mm	575 mm		
Distance Between Centers	3000 mm-8000 mm	3000 mm-10000 mm		
Control	Fanuc 0i-TD (std.) / Siemens 810D (opt.)			
Width Of Bed	990 mm			
Bed Way Of Tailstock	2 flat way and 1 V way			
Headstock				
Spindle Bore	153 mm	230 mm	305mm	405 mm
Spindle Nose	A2-11	A2-15	A2-20	A2-28
Spindle Speed	9-600 rpm	9-500 rpm	7-400 rpm	5-250 rpm
Spindle Center	MT#6			
Spindle Motor	22 / 26Kw (std.) 30 / 37Kw (opt.)			
Turret				
Turret Model	V8-160 hydraulic turret (std.) H4-350-VDI hydraulic turret (opt.) ODT-N-32 servo turret (opt.)	V12-200 hydraulic turret (std.) H4-450-VDI servo turret (opt.) ODT-N-32 servo turret (opt.)		
Tool Size	32 mm (std.) / 40 mm (opt.)			
Tailstock				
Quill Diameter	165 mm rotating quill	200 mm rotating quill		
Quill Stroke	250 mm			
Quill Movement	Hand wheel / motorized (std.) Hydraulic (opt.)			
Body Movement	Motorized (motor through rack and pinion)			
Tailstock Center	MT#6			
Feed				
X-axis Stroke	370 mm	480 mm		
X-axis Ball Screw	Ø40 mm	Ø40 mm		
X-axis Transmission	Direct by coupling	Direct by coupling		
X-axis Servo Motor	3 Kw	4Kw		
X-axis Rapid Traverse	5 M/min	5 M/min		
Z-axis Stroke	3000 mm-8000 mm	3000 mm-10000 mm		
Z-axis Ball Screw	3000-8000 mm Ø80 mm	3000-10000 mm Ø80 mm		
Z-axis Transmission	(B.C 3000-5000 mm) ball screw rotates though 1:4 planetary gear reducer	(B.C 3000-5000 mm) ball screw rotates though 1:4 planetary gear reducer		
	(B.C 6000-8000 mm) Nut rotates through helical gear	(B.C 6000-10000 mm) Nut rotates through helical gear		
Z-axis Servo Motor	4 Kw	7 Kw		
Z-axis Rapid Traverse	4 M/min	4 M/min		
Standard Accessories				
Lubrication Pump	25 w			
Coolant Pump	3 bar (std.) / 15 Bar (opt.)	15 bar		
Hydraulic Pump	3Hp (std.) / 4 Hp (with additional hydraulic units)			
Linear Scale For X / Z Axis	Optional			
Chip Removing System	Rear chip conveyor (std.) Front & Rear chip conveyor (opt.)	Front & Rear chip conveyor (std.)		
Guarding	Front 2 doors and rear splash guard (std.) / Full enclosed guarding (opt.)			
C-axis System	Optional			

Remark : • These specifications are for reference only. The actual specification depends on order.
• 405mm spindle bores are available for LL950 series only.

Spindle motor power curves & torque chart fanuc spindle motor

Model Fanuc α 22/7000i (22/26Kw STD)

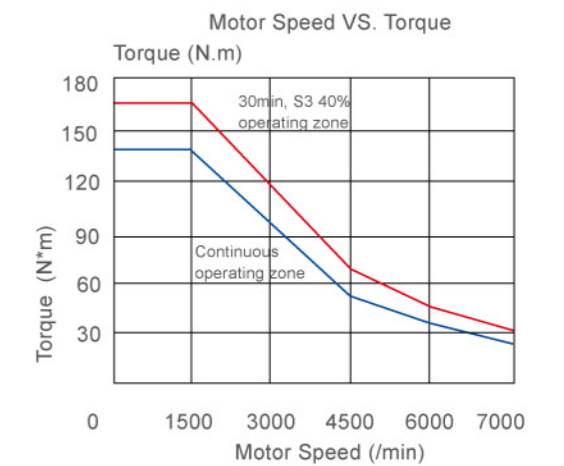
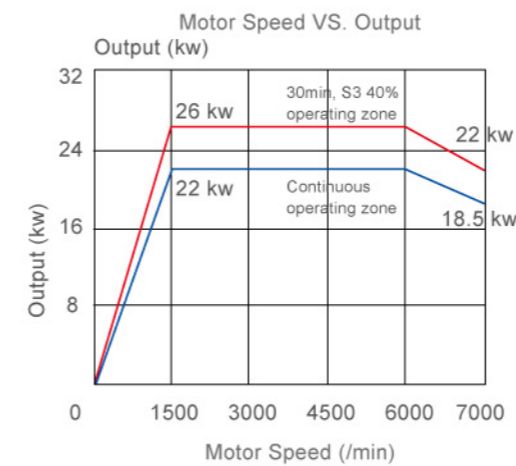

Model Fanuc α 30/6000i (30/37Kw OPT)

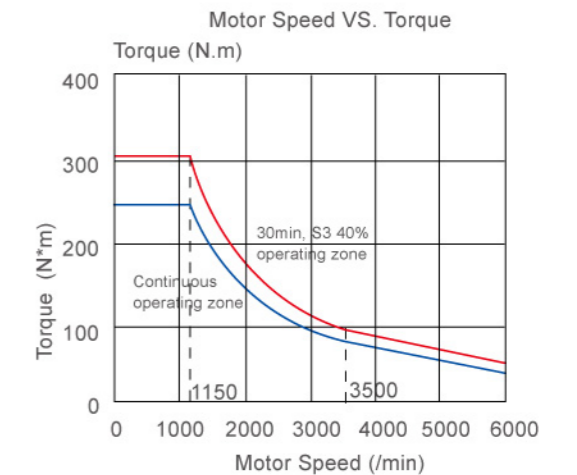
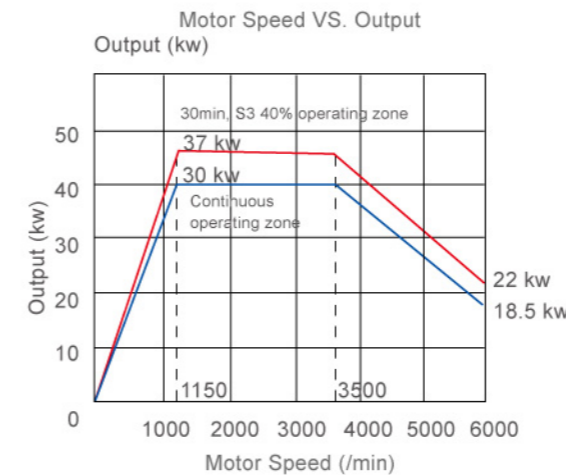

CS AXIS ◀

CS axis rotating angle range	0°~360°
CS axis partition precision	30 arc sec
CS axis rapid traverse	2M/min
CS axis transmission	0.1mm/min~1000mm/min
CS axis movement	belt transmission

