

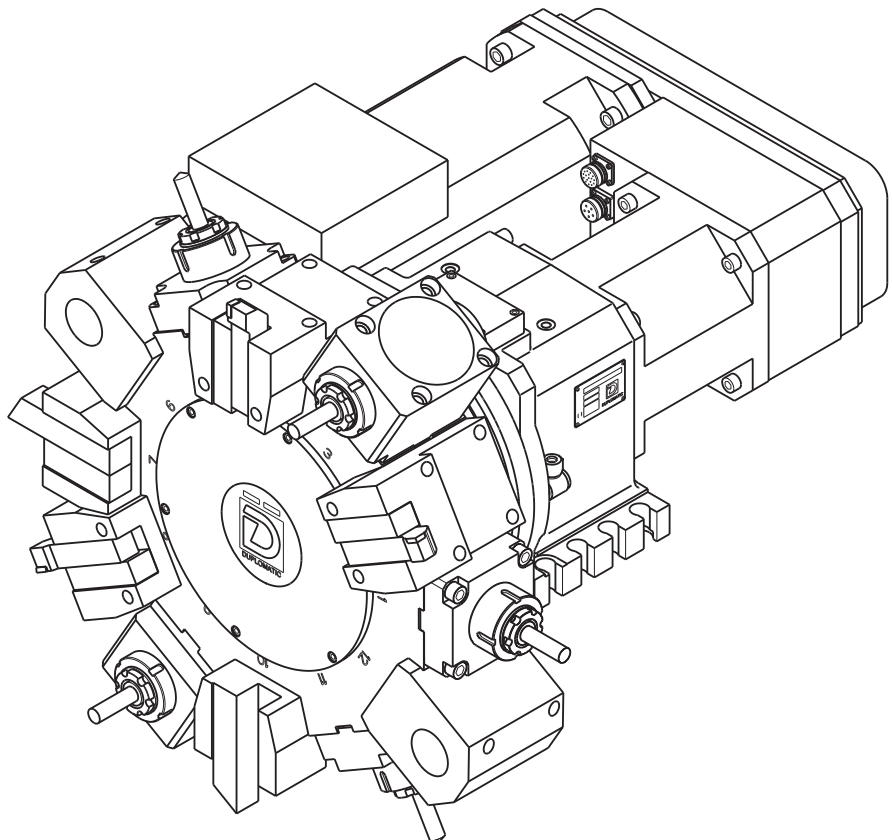

**DIPLOMATIC**  
AUTOMATION



## DM-TR\* series 10

**RADIAL DRIVEN TOOL SYSTEM  
WITH DIRECT MOTOR TURRETS**

(PATENTED)



TECHNICAL INFORMATION

# I.T. 6468



The new **DM-TR** radial driven tool turrets have been developed strictly applying the **Value Engineering** technique, taking benefits of design similarity, reduced number of components and common parts, for a **lean mechanical design**.

**Advanced technology and modern solution for heavy duty CNC Turning Centers.**

#### TURRET

- Based on the last generation **Direct Drive DM** design (patented).
- Hydraulic clamping system.
- High stiffness and accuracy.
- High loading capacity.

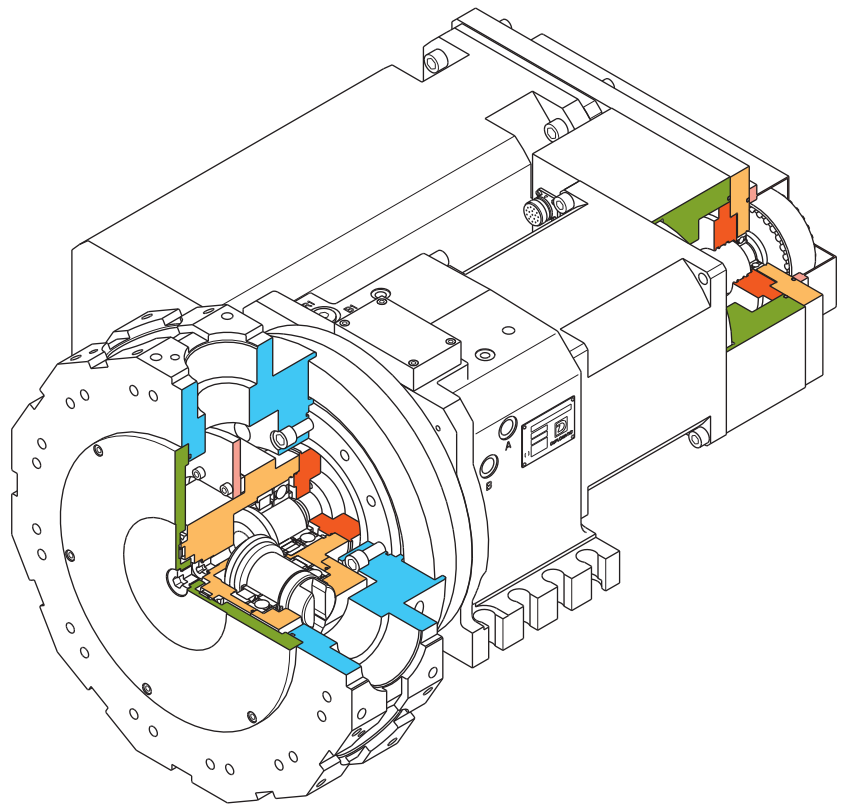

#### DRIVEN TOOL SYSTEM

- New lean mechanical design, based on the original, patented and well known principle of "**automatic engagement without additional devices**", applied to the radial tool disc.
- Specially conceived for the new **BMT tooling system**, granting an oversized **tenon coupling**, but also available for the traditional **DIN 69880 tooling system**.
- High torque and power performances.

### Turret

		DM-TR								
Size		16		20		25				
Tool stations	N°	12		12		12				
Inertia of transportable masses (1)	Kgm <sup>2</sup>	2.2	3.0	3.0	5.0	5.0	9.0			
Positioning times: (2)	one step index time	30°	s	0,23	0,31	0,24	0,31	0,31	0,40	
		180°	s	0,60	0,76	0,66	0,78	0,78	0,98	
	step-less rotation time	30°	s	0,067	0,08	0,08	0,08	0,08	0,08	
(Tsb) Unclamping or (Tb) Clamping time (2)	hydraulic	s	0,14		0,18		0,22			
Indexing frequency	$\alpha = 90^\circ$	Cycle/min	12	10	12	10	11	9		
Indexing accuracy		Deg°	±4"							
Repeatability accuracy		Deg°	±1,6"							
Working pressure	hydraulic	bar	40 ±5		40 ±5		40 ±5			
Required oil volume		cm <sup>3</sup> /cycle	56		123		131			
Electric supply - Inputs / Outputs			see electric diagram							
Mass (complete system without driven tool motor)		Kg	140		220		290			
Ambient temperature range		°C	5 ÷ 40							
Coolant supply :										
Standard : (Filtering ≤ 100 µm)										
• Costant flow		bar			7					
• Pressure cut-off during turret rotation		bar			30					
Protection degree (DIN 40050)			IP 65							

(1) Larger inertia values can be applied with increased indexing times

(2) Conditions: • Hydraulic supply properly sized.

• Without dead-times caused by machine CNC.

### Loading data

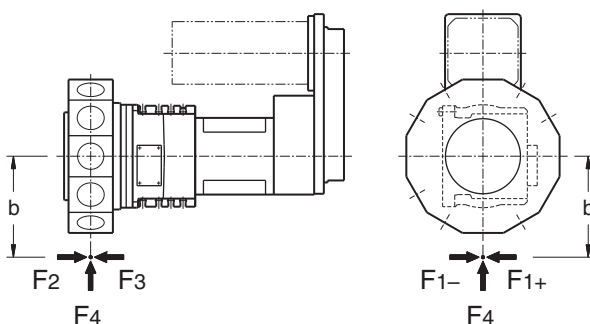

			DM-TR		
			16	20	25
Max. tangential torque	F1xb	Nm	1.800	3.600	7.000
Max. tilting torque to push	F2xb	Nm	2.500	5.200	10.000
Max. tilting torque to lift	F3xb	Nm	2.200	4.500	8.000
Max. radial tilting torque	F4	N	14.000	24.000	35.000
Unbalancing torque (during turret rotation)		Nm	22	40	60

(3) Safety factor ≥ 1,3.

### Tool drive

		DM-TR		
Size		16	20	25
Max torque [S3 – 40% 10 min.]	(4) Nm	30	50	70
Max speed at the spindle	RPM	6.000	5.000	4.000
Transmission ratio	$\tau$	1:1	1:1	1:1
Coupling		see sheets 10 and 11		

- (4) These values are valid for free-shock operations.  
In case of interrupted-cut or other shock-operations, a reduction of these values up to 50% must be considered.

### Motor (optional) (5) (6)

		DM-TR		
Size		16	20	25
Siemens A.C. Motor	type	1FT 6084	1FT 6086	1FT 6105
— Torque	S1 / S3 - 40% - 10 min	20 / 25	27 / 35	48 / 60
— Max speed	RPM	6.000	5.000	4.000
Fanuc A.C. Servomotor	type	$\alpha$ iS22	$\alpha$ iS30	$\alpha$ iS50
— Torque	S1 / S3 - 40% - 10 min	18 / 26	30 / 47	50 / 75
— Max speed	RPM	6.000	4.000	3.000
Fanuc A.C. Spindle motor	type	$\alpha$ 2	$\alpha$ 3	$\alpha$ 6
— Torque	S1 / S3 - 40% - 10 min	14 / 24	23,5 / 35	35 / 50
— Max speed	RPM	6.000	5.000	4.000

- (5) Servomotor with "**orientation function**" by CNC must be used.  
(6) Other motors on request.

### INDICATIVE CUTTING CAPACITY

for 600 N/mm<sup>2</sup> steel, HSS tools  
(With fit motors)

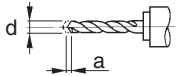
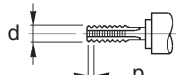
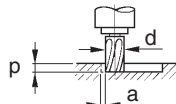
		DM-TR			
		16	20	25	
Twist drilling	$d \times a$ [mm] x [mm/u]		16 x 0,20	22 x 0,20	25 x 0,25
Tapping	$d \times p$ [mm] x [mm]		M12 x 1,75 M18 x 1,5	M16 x 2,0 M30 x 1,5	M18 x 2,5 M30 x 2,0
Slot milling	$d \times p \times a$ [mm] x [mm] x [mm/min]		22 x 10 x 40	25 x 15 x 40	32 x 18 x 40

**NEW BMT TOOLING SYSTEM**

- Size range from 45 to 75.
- 4 bolts fitting system to maximize cutting rigidity.
- 2 keys and centering diameter reference system to reach the best positioning accuracy.
- Oversize tenon coupling to grant high torque and power transmission.

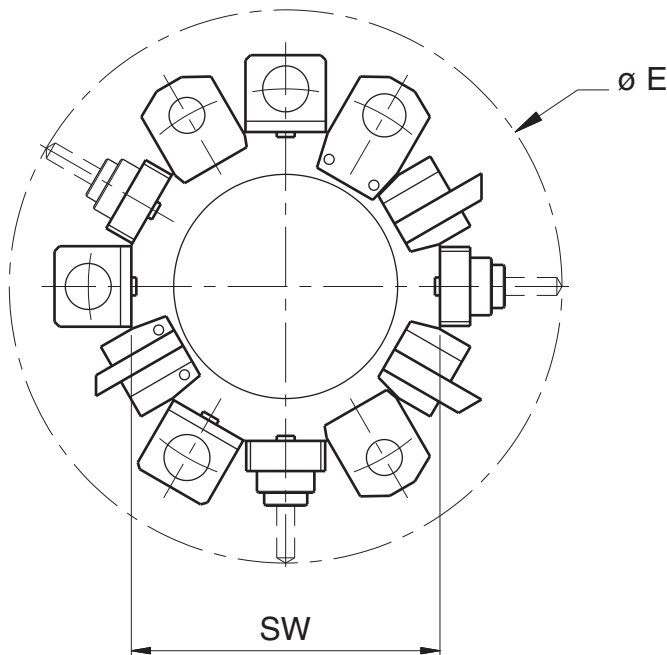
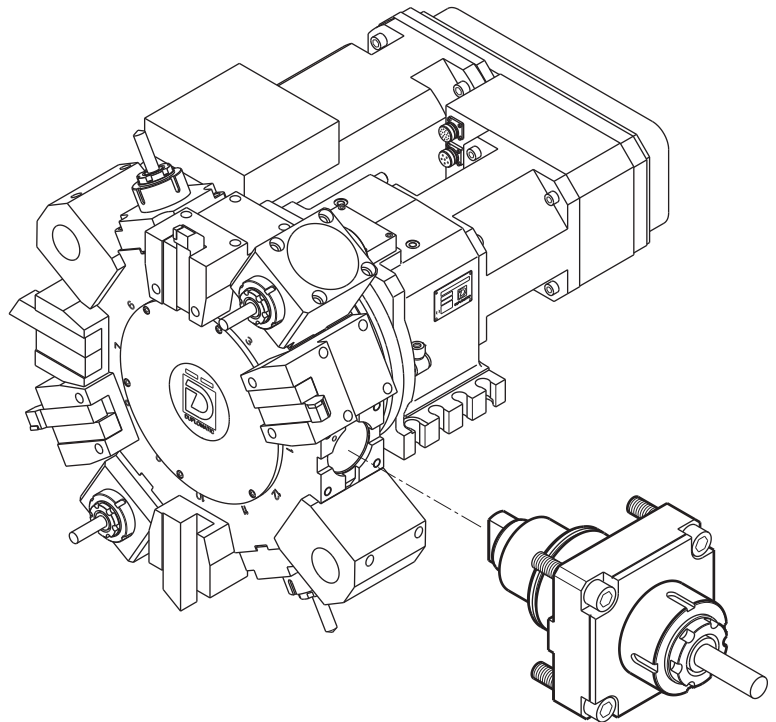

<b>BMT size</b>		<b>45</b>	<b>55</b>	<b>65</b>	<b>75</b>
Disc size	SW min.	290	330	380	430
Indicative tool swing	$\varnothing E$	500	580	625	715

Matching DM-TR turret size	<b>16</b>	<b>20</b>	<b>25</b>
----------------------------	-----------	-----------	-----------

**DIN 69880 traditional TOOLING SYSTEM**

- Size range from 25 to 50.
- Tenon coupling DIN 1809.
- Same rotating toolholders of axial ODT-N driven tool system.

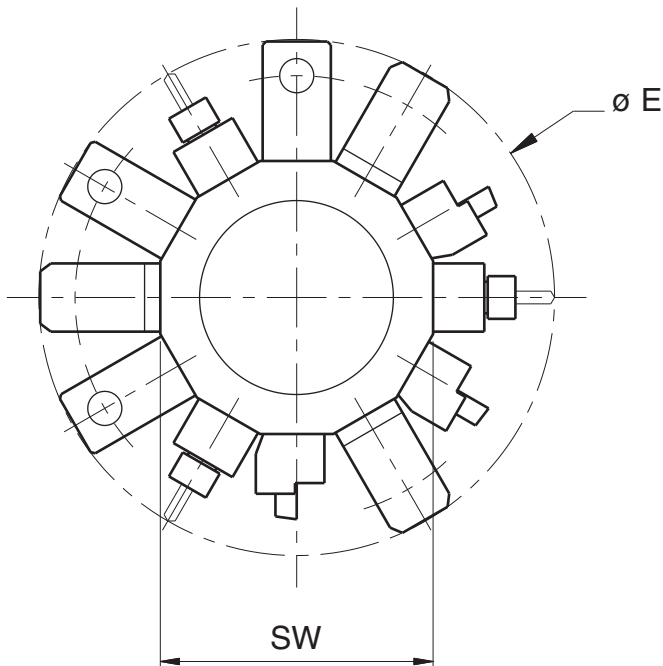
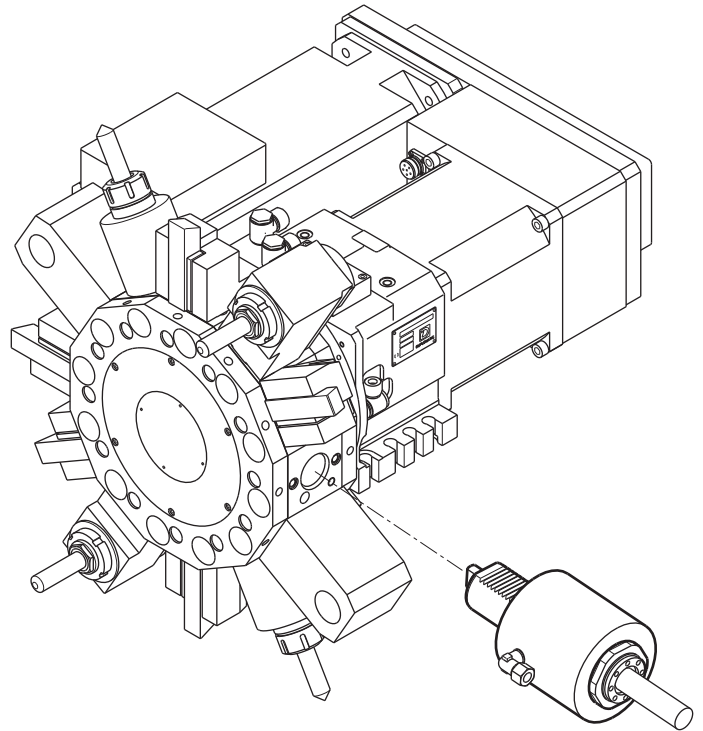

<b>DIN 69880 size</b>		<b>25</b>	<b>30</b>	<b>40</b>	<b>50</b>
Disc size	SW min.	240	270	320	380
Indicative tool swing	øE	460	550	610	720
<b>Matching DM-TR turret size</b>		<b>16</b>	<b>20</b>	<b>25</b>	

**STANDARD**

- Front machining only
- Same height as stand-alone **DM** turrets
- Same foot print as stand-alone **DM** turrets

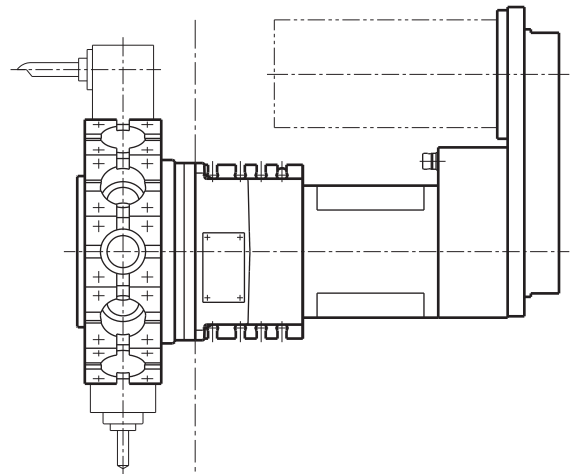

**BM1**

- Front and back-machining
- Same height as stand-alone **DM** turrets
- Foot print "compatible" with stand-alone **DM** turrets

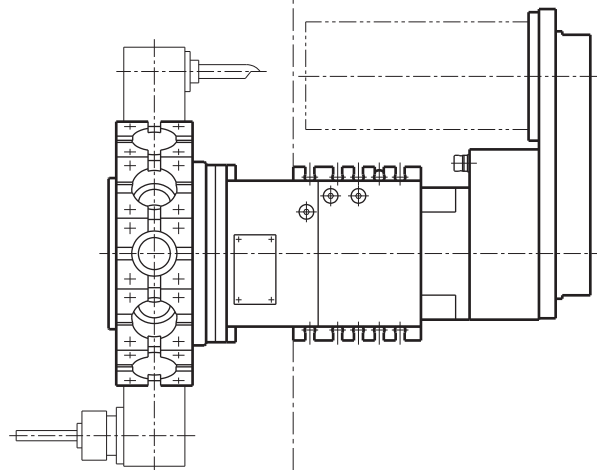

**BM2**

- Front and back-machining
- Same height as **SM-BR** driven turrets
- Foot print "compatible" with **SM-BR** driven turrets

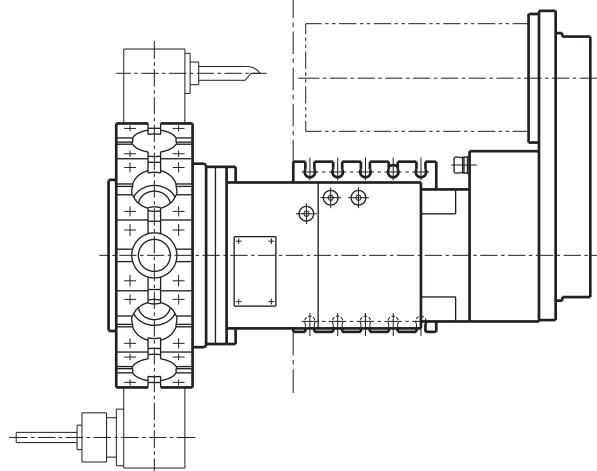



# DM-TR\* / series 10

## TURRET AND DISC VERSIONS

### BMT TOOLING

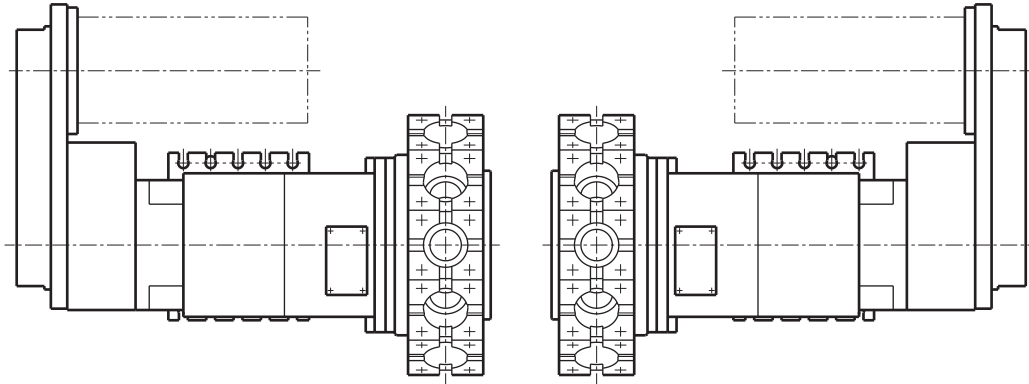

**S1**  
**LEFT TURRET**

**D1**  
**RIGHT TURRET**

NOTE: The BMT tool disc is always the same.

### DN 69880 TOOLING

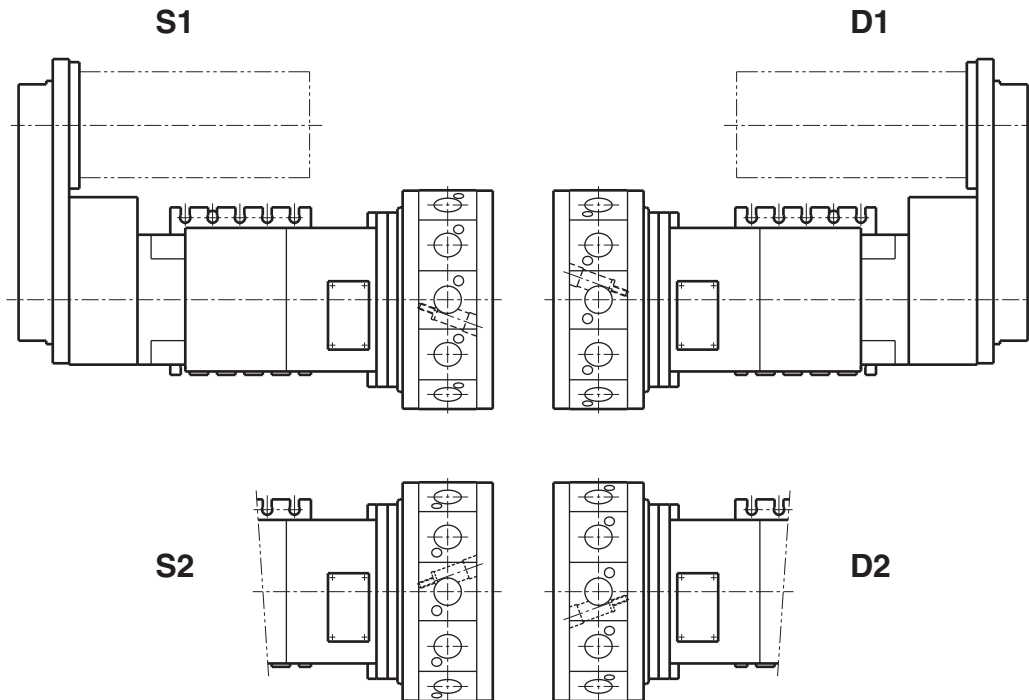

	<b>S2</b>	<b>S1</b>	<b>D2</b>	<b>D1</b>
Turret	Left	Left	Right	Right
Tool disc	Left	Right	Left	Right

**WORKING POSITION:**

- STANDARD: at "3 o'clock" for right turrets.  
at "9 o'clock" for left turrets.

- Different working positions, on request.

### BMT TOOLING SYSTEM

- Coupling specs**

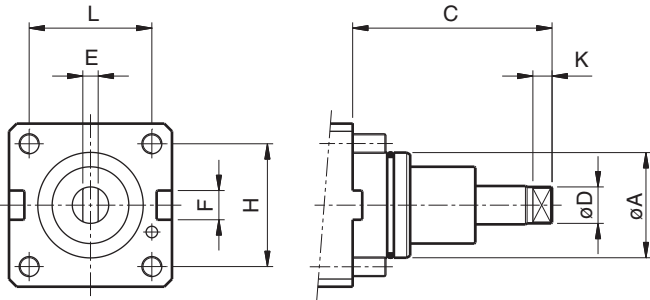

DM-TR size	16	20	25	
BMT $\phi A$	45	55	65	75
C	84	104	112	110
K	8	10	14	15
D	18	19 (max 22)	22 (max 27)	29 (max 32)
E <sup>h12</sup>	6	8	10	14
L	58	64	70	90
H	58	64	73	90
F	15	15	18	25

[mm]

- Tool disc seats protection**

Housing not engaged with toolholders must be properly plugged:

- Plugs supplied with the disc
- Additional cover (not supplied)

Housing engaged with static toolholders must be properly plugged:

- Plugs supplied with the disc

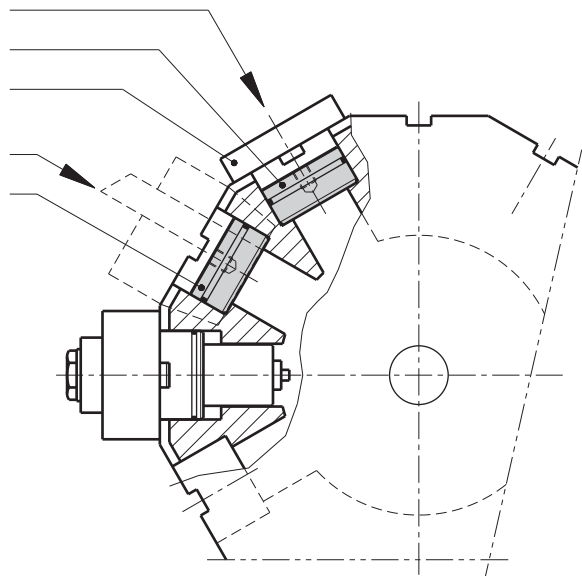

- Tool clamping**

- It is recommended to clamp the tools with two wrenches. The use of one only wrench causes damages the driven tool center module.
- This plate is supplied with the DM-TR turret, and it must be fitted on the machine so as to be very clearly seen.

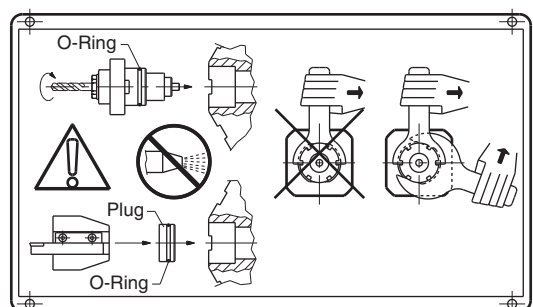

### DIN 69880 TOOLING SYSTEM

- Coupling specs DIN 1809**

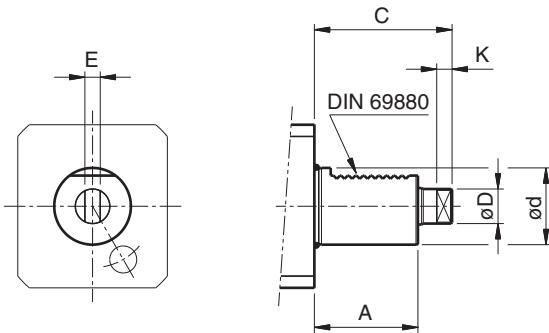

DM-TR size	16		20	25
DIN 69880 size	25	30	40	50
$\varnothing d^{h6}$	25	30	40	50
<b>A</b>	41,5	50,5	56	71
<b>C</b>	57	62	72	92
<b>K (min)</b>	7	7	6,5	13
$\varnothing D$	12	12	18	24
<b>E<sup>h12</sup></b>	6	6	8	13

[mm]

- Angular adjusting pins on disc (for radial rotating units)**

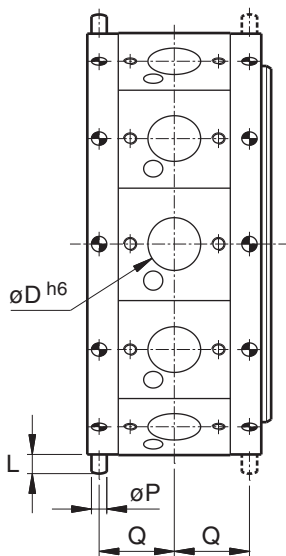

	$\varnothing D$	$\varnothing P$	Q	L
<b>DM-TR 16</b>	25	8	40	10
	30	8	48	10
<b>DM-TR 20</b>	40	10	56	15
<b>DM-TR 25</b>	50	10	64	15

[mm]

- Tool clamping**

- It is recommended to clamp the tools with two wrenches. The use of one only wrench causes damages the driven tool center module.
- This plate is supplied with the DM-TR turret, and it must be fitted on the machine so as to be very clearly seen.
- Housing not engaged with toolholders must be properly plugged (DIN 69880 Shape Z2).

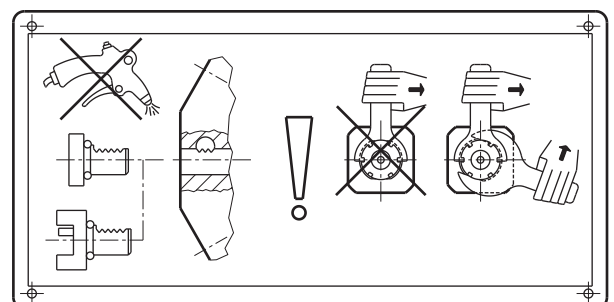

### FRONT Machining only

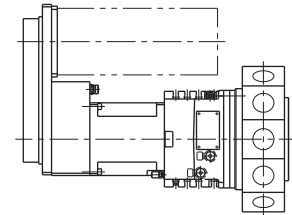
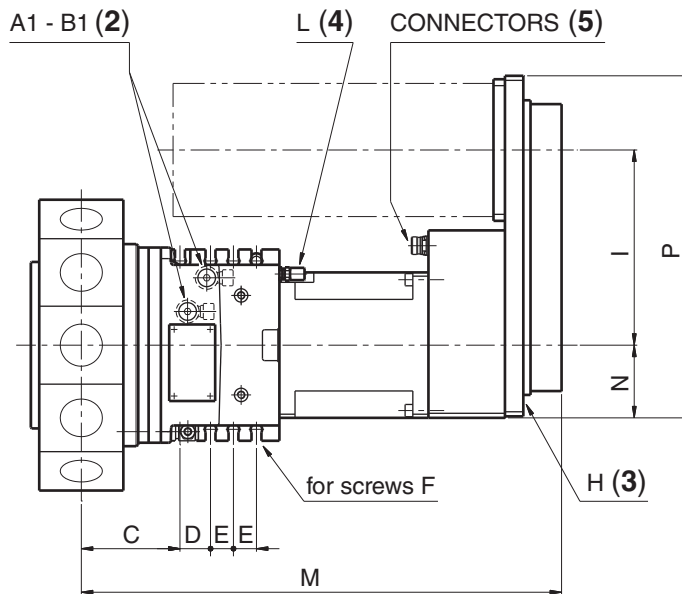
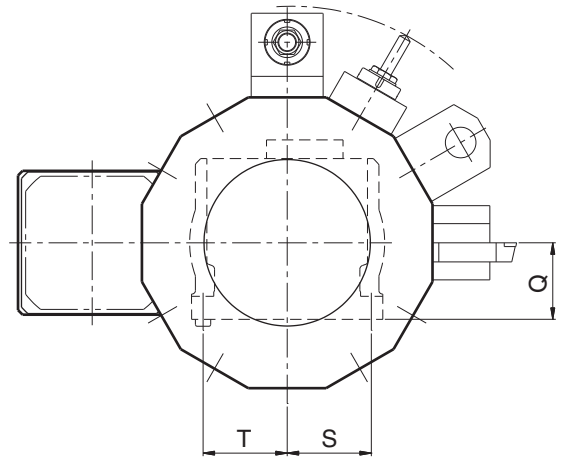
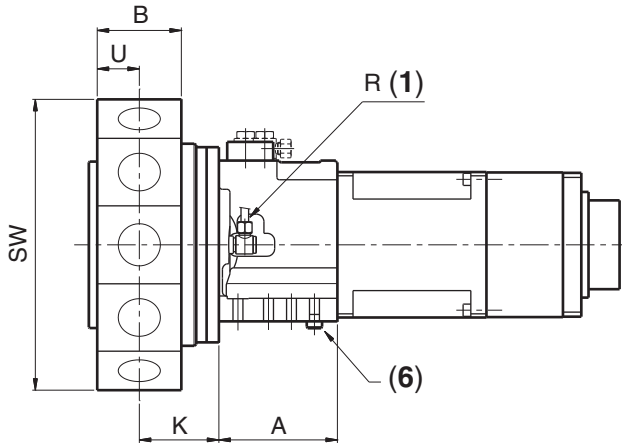

LEFT VERSION: overall dimensions are mirror-image

DM-TR SIZE	A	C	D	E	F	K	I	M	N	P	Q	S	T
16	135	113	32	32	M10	95	216	561	80	387	80	95	95
20	155	129	40	30	M12	104	256	628	95	447	100	110	110
25	186	185	44	43	M16	155	256	710	95	447	125	140	140

[mm]

- 1) Inlet coolant.
- 2) Hydraulic connections.
- 3) Centralized lubrication inlet.
- 4) Safety valve.
- 5) Electrical connectors.
- 6) Reference pin.

TOOL DISC DM-TR SIZE	BMT TOOLING				DIN 69880 TOOLING			
	SIZE	SW	B	U	SIZE	SW	B	U
16	45	290	90	45	25	240	92	46
	55	330	100	50	30	270	109	54
20	65	380	110	55	40	320	132	66
25	75	430	115	57,5	50	380	148	74

[mm]

### BM1 Front and back-machining

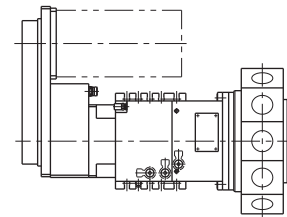
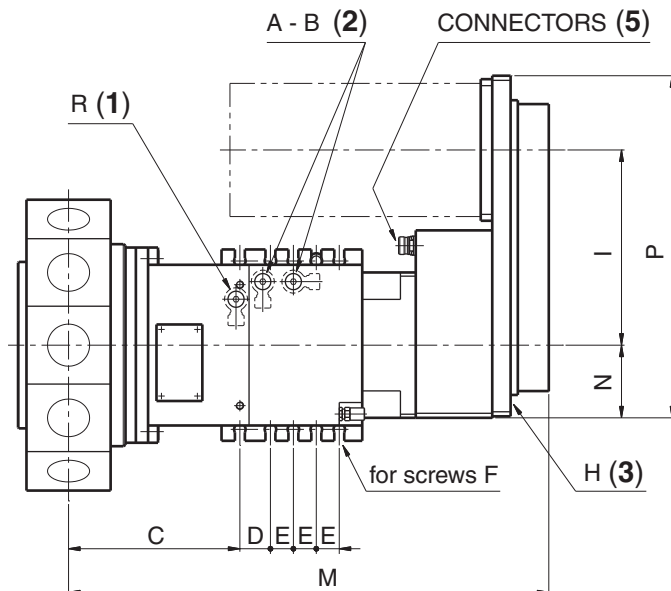
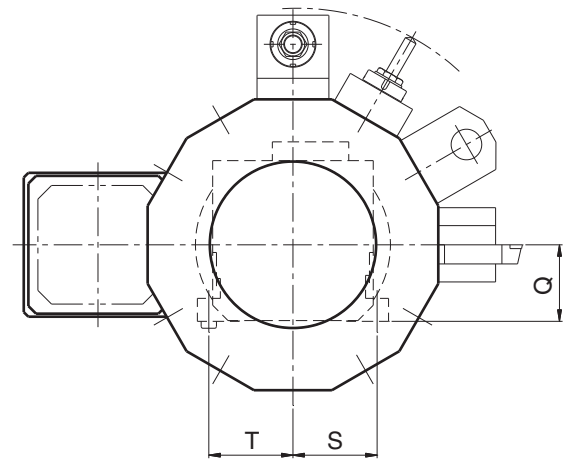
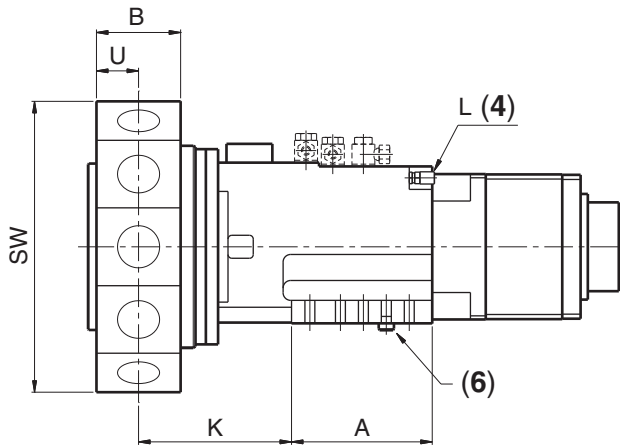

LEFT VERSION: overall dimensions are mirror-image

DM-TR SIZE	A	C	D	E	F	K	I	M	N	P	Q	S	T
16	167	182	32	32	M10	160	216	561	80	387	80	95	95
20	184	224	40	30	M12	200	256	628	95	447	100	110	110
25	229	280	44	43	M16	250	256	710	95	447	125	140	140

[mm]

- 1) Inlet coolant.
- 2) Hydraulic connections.
- 3) Centralized lubrication inlet.
- 4) Safety valve.
- 5) Electrical connectors.
- 6) Reference pin.

DM-TR SIZE	BMT TOOLING				DIN 69880 TOOLING			
	SIZE	SW	B	U	SIZE	SW	B	U
16	45	290	90	45	25	240	92	46
	55	330	100	50	30	270	109	54
20	65	380	110	55	40	320	132	66
25	75	430	115	57,5	50	380	148	74

[mm]

### BM2 Front and back-machining

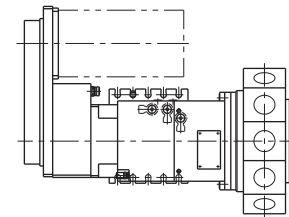
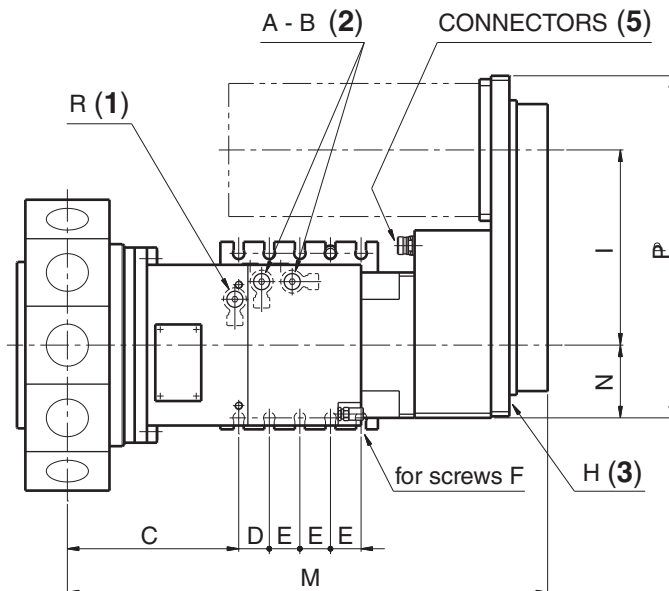
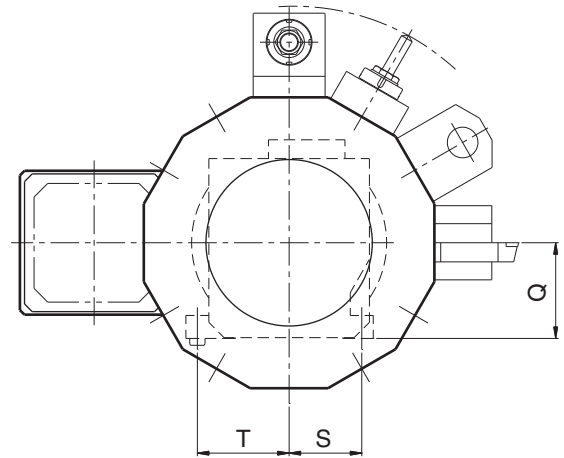
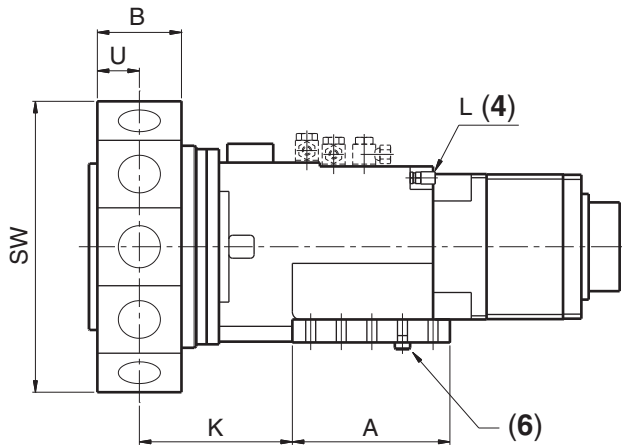

LEFT VERSION: overall dimensions are mirror-image

DM-TR SIZE	A	C	D	E	F	K	I	M	N	P	Q	S	T
16	185	182	34	34	M10	160	216	561	80	387	100	90	90
20	206	224	40	40	M12	200	256	628	95	447	125	95	120
25	248	280	47	47	M16	250	256	710	95	447	150	125	155

[mm]

- 1) Inlet coolant.
- 2) Hydraulic connections.
- 3) Centralized lubrication inlet.
- 4) Safety valve.
- 5) Electrical connectors.
- 6) Reference pin.

TOOL DISC DM-TR SIZE	BMT TOOLING				DIN 69880 TOOLING			
	SIZE	SW	B	U	SIZE	SW	B	U
16	45	290	90	45	25	240	92	46
	55	330	100	50	30	270	109	54
20	65	380	110	55	40	320	132	66
25	75	430	115	57,5	50	380	148	74

[mm]

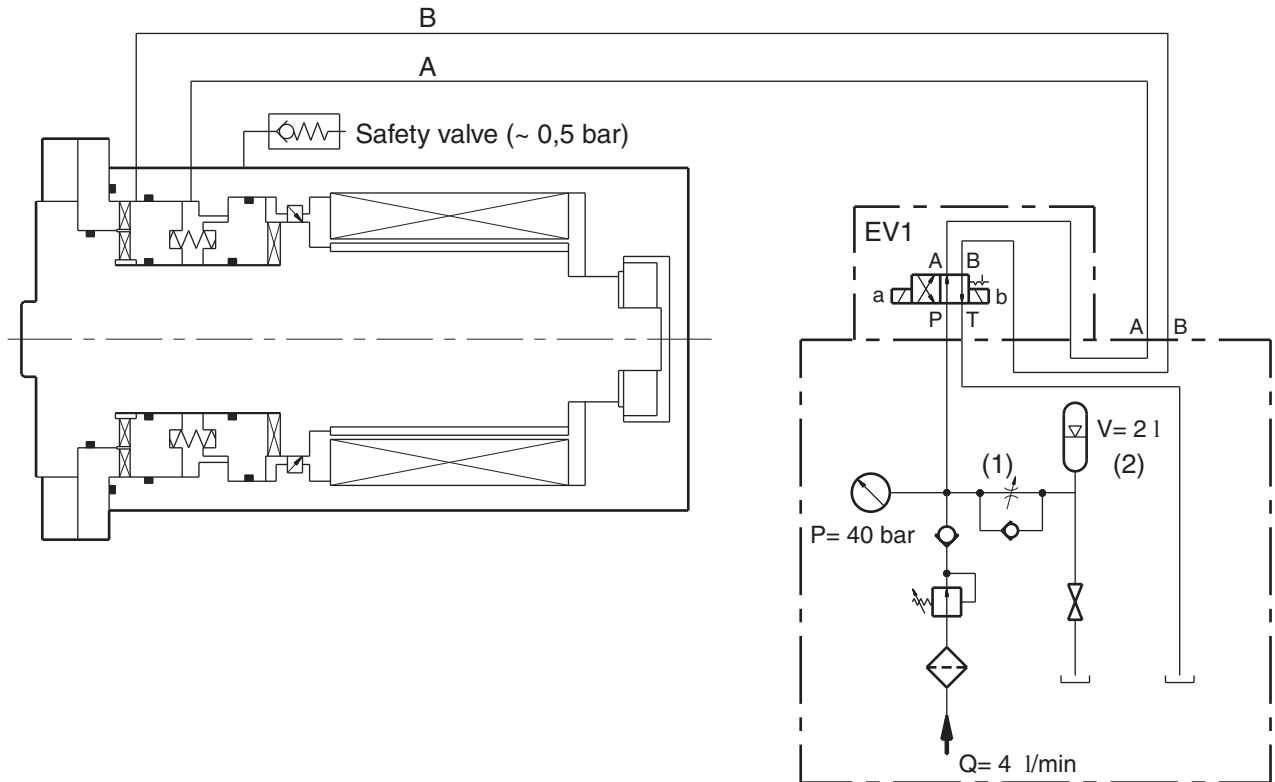

HYDRAULIC POWER PACK (Example)

- (1) **IMPORTANT:** A flow adjustment valve must be foreseen in order to avoid a violent or noisy clamping.
- (2) The accumulator's volume is according to the real pump flow rate.

Supply:

- Working pressure ..... 40 ±5 bar
- Filtering ..... 20 µm
- Oil viscosity ..... 32 ÷ 46 mm<sup>2</sup>/s
- Recommended oil temperature 35 ÷ 55 °C

Size	DM-TR	16	20	25
Required oil volume [cm <sup>3</sup> ]	Clamping	28	61,5	65,5
	Unclamping	28	61,5	65,5
Needed instant flow [l/m] for Tb		12	20,5	19
		0,14 s	0,18 s	0,22 s

Functions	EV1	
	sol. a	sol. b
Clamping turret	-	+
Unclamping turret	+	-

Connections on the turret				
A – (A1)	GAS	1/4"	3/8"	3/8"
B – (B1)	GAS	1/4"	3/8"	3/8"

DN recommended nominal diameter for hydraulic line				
Lenght	≤ 6 m	8	10	10
	> 6 m	10	12	12

The **DM-TR turret** has been preset with a lubrication function, that can be used in order to prevent wearing increasing due to heavy driven tool duty cycle.

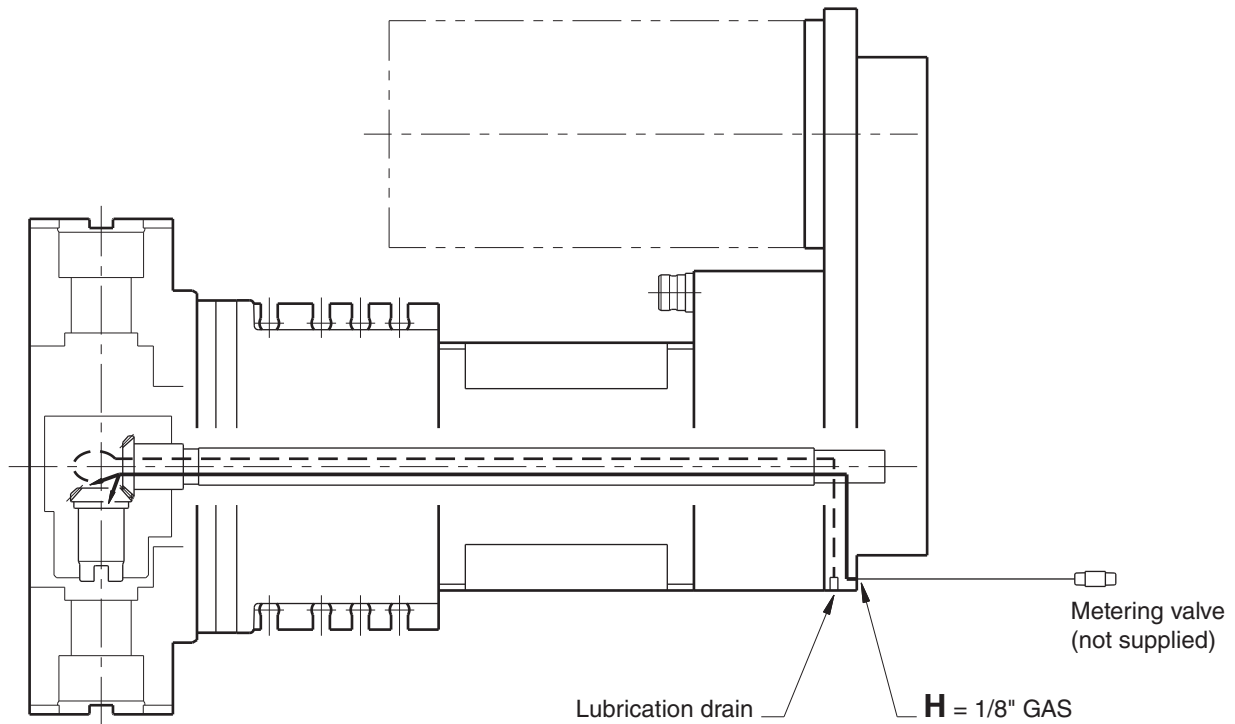

### H • LUBRICATION INLET:

- Lubrication supply:
  - Required oil volume : ..... 0,06 cm<sup>3</sup>/ cycle
  - Lubrication frequency : ..... 6 cycle / h  
*Note:* Depending on driven tool duty cycle.
  - Type of lubricant : Oil with viscosity ≤ 750 cSt (40°) or fluid grease.

**WARNING:** If oil contamination inside the working area is not allowed, please contact our Technical Dept.



The **DM-TR\*** turrets are supplied with a proper **TMC-\* Direct motor driver** for remote installation inside the machine electrical cabinet.

The turret-side electrical connections are carried-out by connectors.

**IMPORTANT** : In the machine electrical cabinet proper electrical protection devices must be foreseen. (i.e. fuses).

For all details and specs about electrical connections and interfacing to CNC, please refer to relevant Electrical Manual **E.M. TMC-\***.

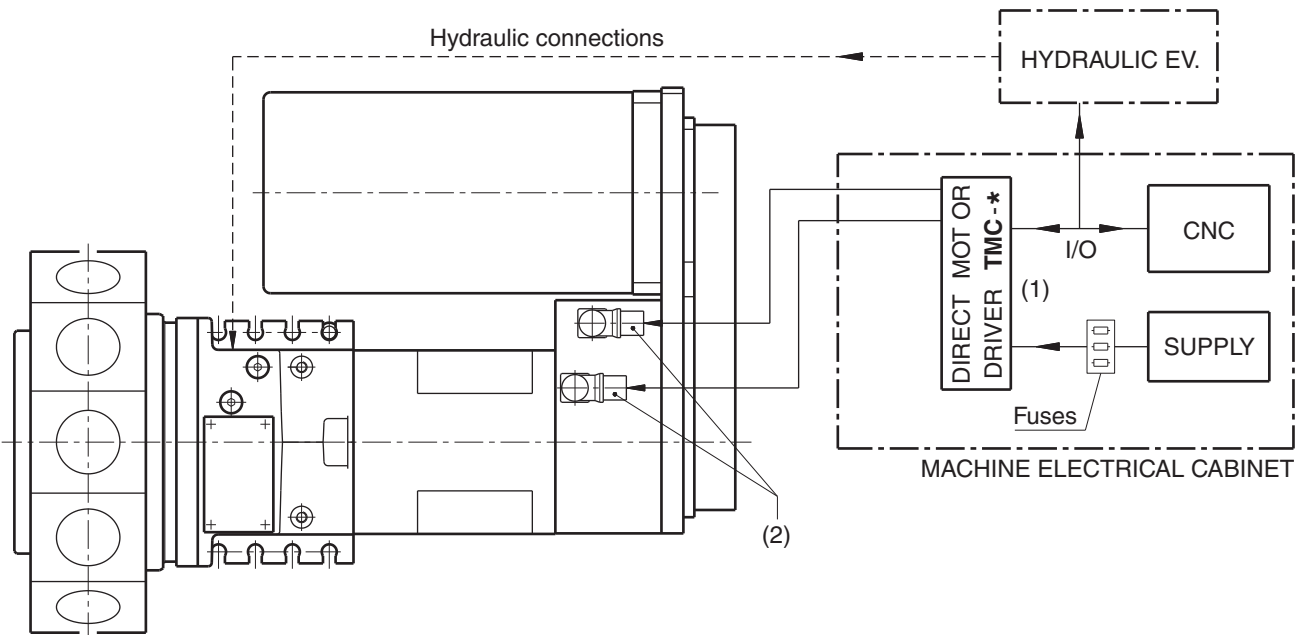

- (1) Included in our supply : **TMC-\* Direct motor driver.**  
 Excluded from our supply : Fuses and whatever not clearly mentioned.  
 (2) Connectors (Turret side).

SUPPLY	DM-TR*	
• Power input 3~	400VAC +15% -10% 16A max	230VAC +15% -10% 23A max
• Auxiliary supply DC	24VDC ±10% 50W	
• Frequency range	50/60Hz ±2Hz	
SPECS FOR POWER TRANSFORMER:		
• Secondary rate voltage	400 VAC ±10% - 3~	230 VAC ±10% - 3~
• RATED POWER	1,5 KVA	
• Max voltage drop at 16A RMS	5%	
• Connections	STAR-STAR / DELTA STAR	
• Secondary voltage deviation	±2%	

INPUTS	DM-TR*
• Voltage range	24 Vd.c. ±10%
• Current	5mA (24 Vd.c.)
<b>OUTPUTS</b>	
• Transistor MOS N.O. (source)	
• Max voltage	24 Vd.c. ± 10%
• Max current	2,0A (Power) 30mA (Signal)
• Operating temperature (turret)	0 ÷ 55°C
• Humidity	30 ÷ 95%
• Vibration:	1 G max

**Overall dimensions**

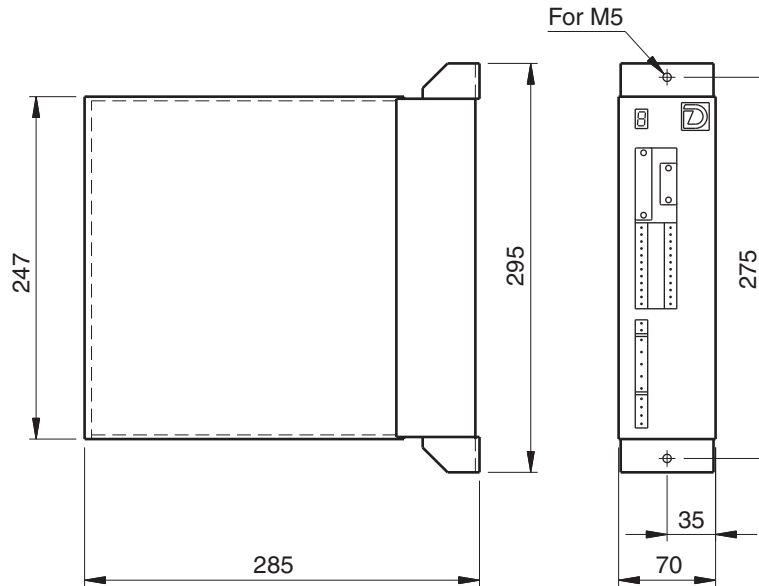

**NOTE:** Foresee at least 20 mm of free space on both sides and at least 100 mm above and below to allow connections and cooling airflow.

**How to connect**

**POWER CONNECTORS**

		CABLE SIDE
CN10	AC supply 3 ~	Phoenix GMSTB 2,5/4-ST-7,5
CN11	Motor power	Phoenix GMSTB 2,5/5-ST-7,5

**SIGNAL CONNECTORS**

		CABLE SIDE
CN1	Digital OUTPUTS	Phoenix MSTB 2,5/12-ST
CN2	Digital INPUTS	Phoenix MSTB 2,5/12-ST
CN8	24VDC	2P female 5mm-CPF 5/2
CN7	Signal to/from turret	SUB-D 25 male DIN 41652 (1)
CN9	RS232 serial connection	SUB-D 9 female DIN 41652 (1)

(1) Not supplied

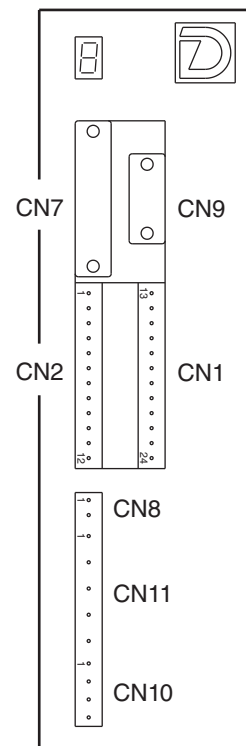

# DM-TR\* / series 10

## ELECTRICAL CONNECTORS

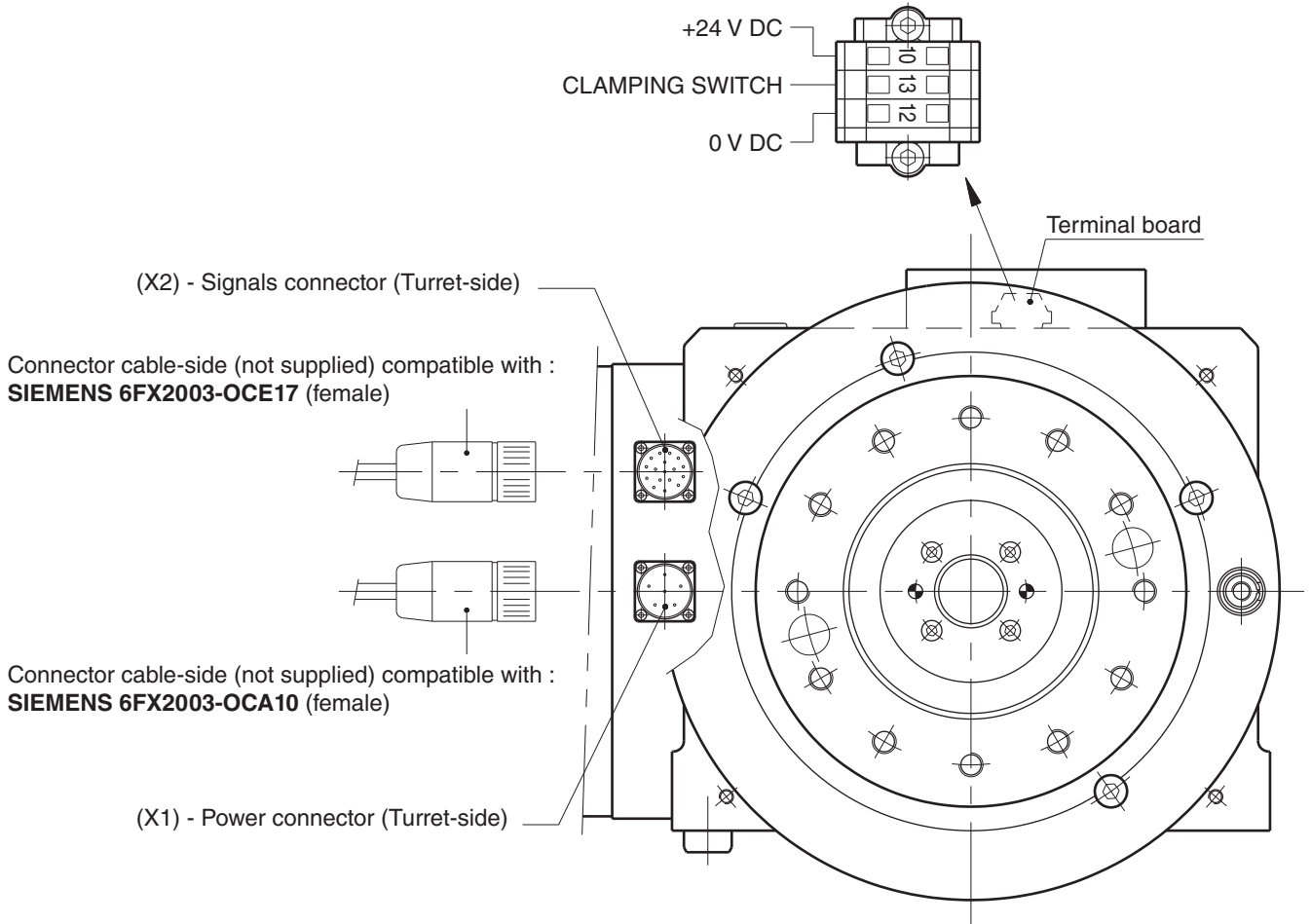

**NOTE:** On DM-TR16 size the connectors are in the top position.

### Connectors (Turret-side)

**(X1) POWER:**  
Panel mount socket for male contacts.

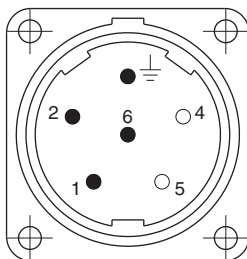

— View from mating side  
— Contacts 4 and 5 not used.

**NOTE:**  
– Turrets size 16: model **M23-6 pin-male-CW-90°**  
– Turrets size 20 / 25: model **AFEA 06 CMRSN 000 male**

**(X2) SIGNAL:**  
Panel mount socket for male contacts (n° 17).

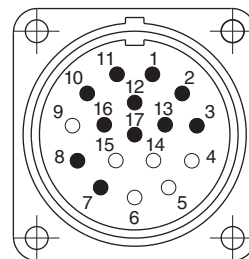

— View from mating side.  
— Contacts 4-5-6-9-14-15 not used.

**NOTE:**  
– Turrets size 16: model **M23-17 pin-male-CW-90°**  
– Turrets size 20 / 25: model **SFOA 17A MREN 000 male**

### TURRET

The **DM-TR\*** turrets are supplied with the **TMC-\* Direct motor driver** that drives the complete indexing cycle to the position required from the machine CNC.

For all details and specs about electrical connections and interfacing to CNC, please refer to relevant Electrical Manual: **E.M. TMC-\*\*\***.

### DRIVEN TOOL SYSTEM

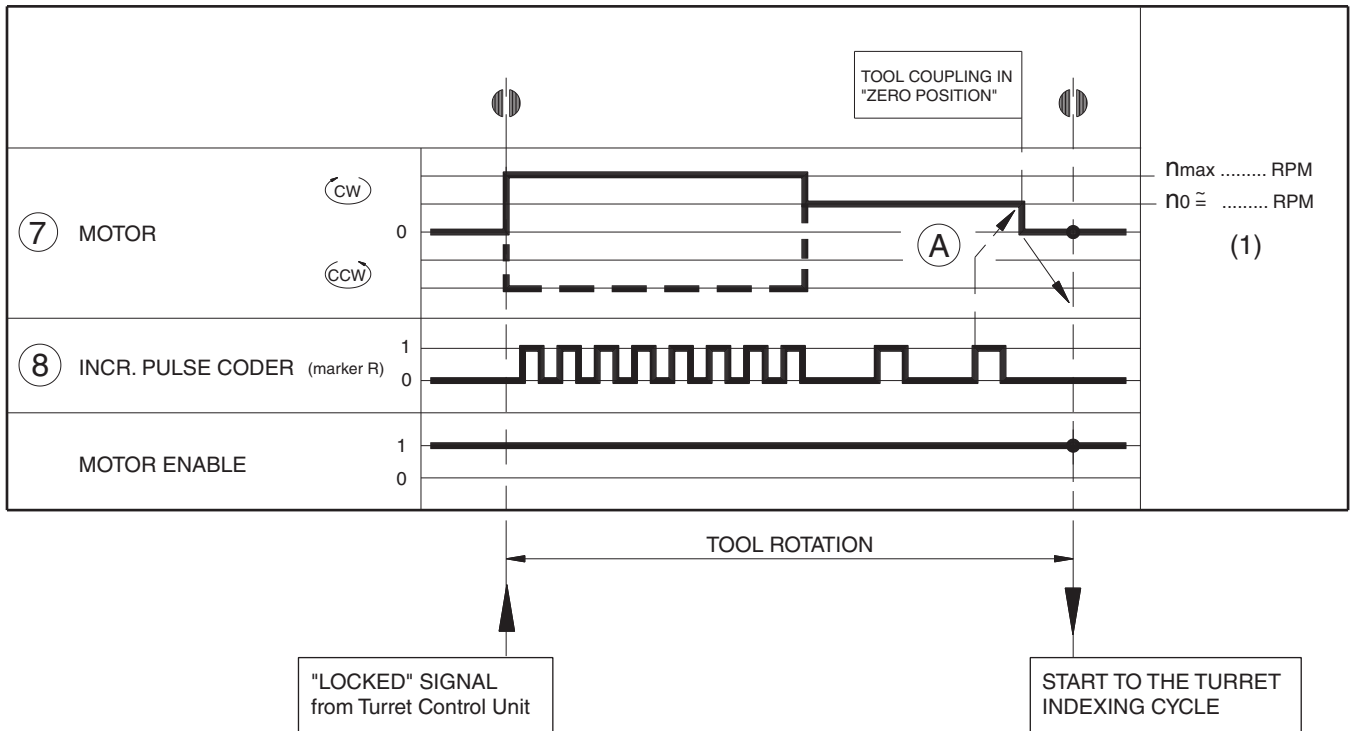

#### IMPORTANT :

Servomotor with "orientation function" by CNC must be used.

- 1) • Max motor speed for tool rotation:
  - $n_{max}$  = see sheet 5.
  - The motor speed  $n_0$  for tool zero setting must be according to CN/ driver specs.
- 2) Motor driver enable must be always "ON" , keeping the zero position, to allow the turret rotation.  
**Important :** If servomotor with brake is used, the driver can be "disable" at the end of orientation, always keeping on the brake and the motor position control.

(A) The distance between coder marker and driven tool coupling zero position must be set.

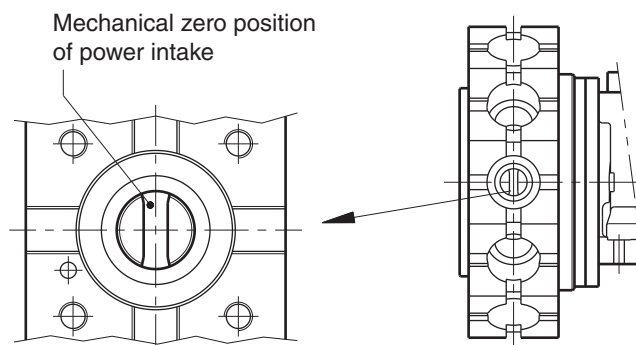

**DRIVEN TOOL CYCLE START**

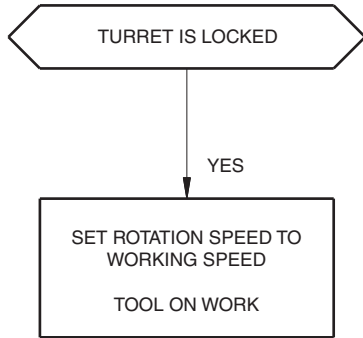

**ZERO SETTING CYCLE**

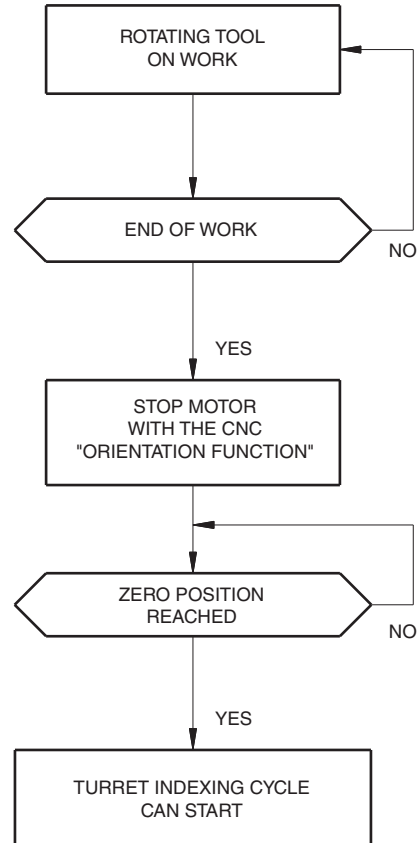

**IMPORTANT :**  
Motor driver must be always "ON",  
keeping the zero position

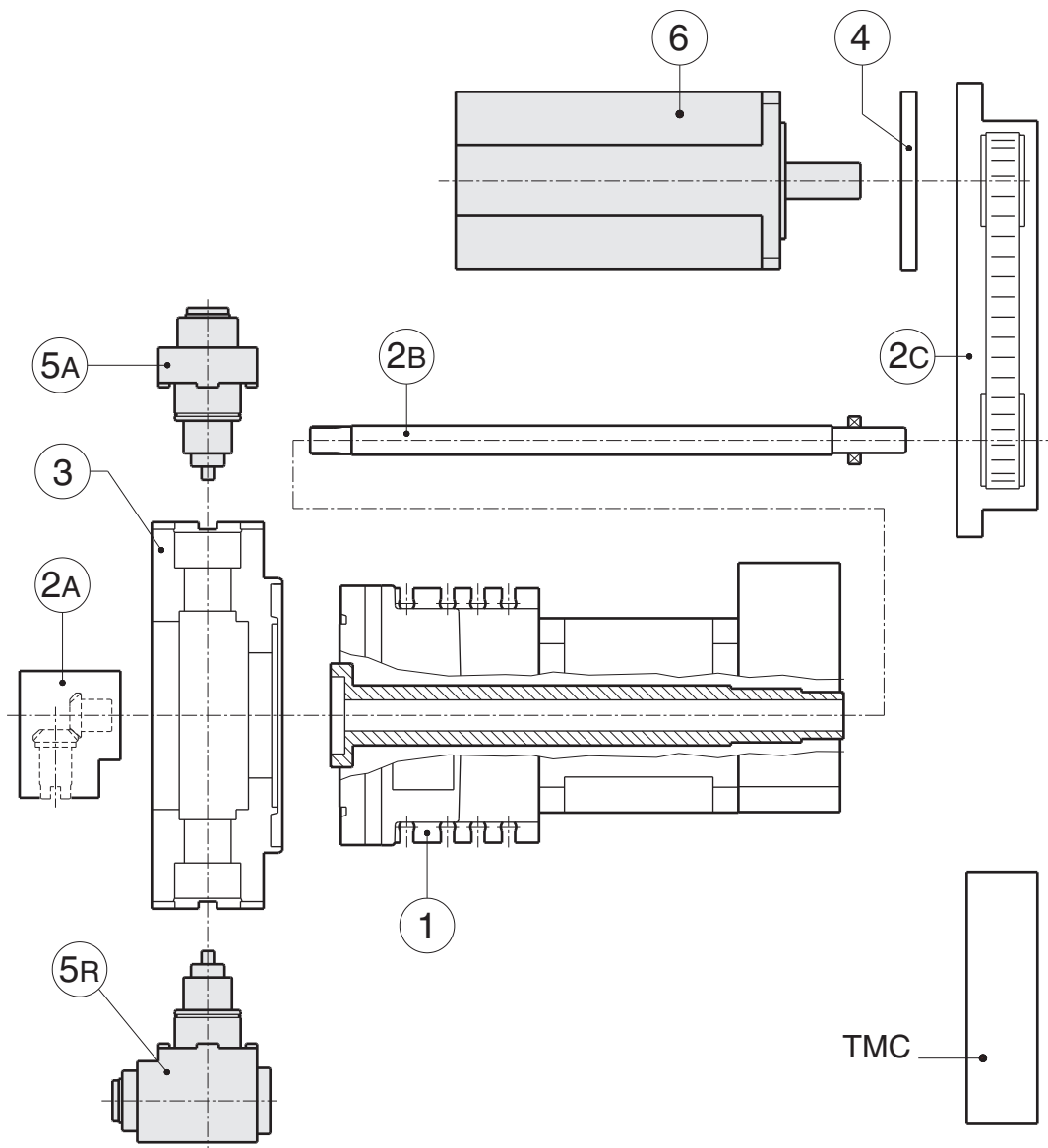

(1) Turret with axial through-bore:

**DM-\* PA/series 10**

(complete with **TMC** Control Unit).

(2) **Radial driven tool system:**

2A - Drive central module.

2B - Co-axial drive shaft.

2C - Rear box.

(3) Radial Tool disc, BMT or DIN 69880.

(4) Motor interface group.

**OPTIONALS:**

(5) Rotating toolholders, BMT or DIN 69880.

**EXCLUDED:**

(6) Motor for driven tools.



**DIPLOMATIC AUTOMATION S.r.l.**  
20025 LEGNANO (MI) - ITALY  
P.LE BOZZI, 1  
PHONE 0331/472111  
FAX 0331/455161



**DIPLOMATIC**  
AUTOMATION

e-mail: [info@diplomatic.it](mailto:info@diplomatic.it)

come visit Diplomatic homepage:  
[www.diplomaticautomation.com](http://www.diplomaticautomation.com)